

OWNER'S GUIDE

FIFTY CENTS

**MODEL
NO.
149-820A**

**ASSEMBLY
OPERATION
PARTS
MAINTENANCE**

GARDEN TRACTOR

**IMPORTANT:
READ SAFETY RULES
& INSTRUCTIONS**

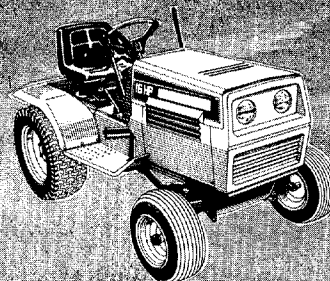
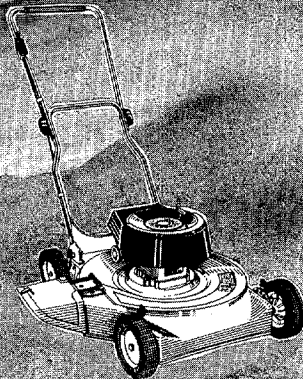
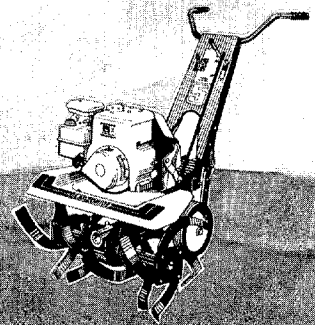
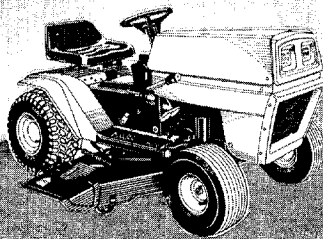

LIMITED WARRANTY

For one year from the date of original retail purchase, MTD PRODUCTS INC will either repair or replace, at its option, free of charge, F.O.B. factory or authorized service firm, any part or parts found to be defective in material or workmanship. Transportation charges under this warranty must be paid by the purchaser unless return is requested by MTD PRODUCTS INC.

This warranty will not apply to any part which has become inoperative due to misuse, excessive use, accident, neglect, improper maintenance, alterations, or unless the unit has been operated and maintained in accordance with the instructions furnished. This warranty does not apply to the engine, motor, battery, battery charger or component parts thereof. Please refer to the applicable manufacturer's warranty on these items.

This warranty will not apply where the unit has been used commercially.

Warranty service is available through your local authorized service dealer or distributor. If you do not know the dealer or distributor in your area, please write to the Customer Service Department of MTD.

The return of a complete unit will not be accepted by the factory unless prior written permission has been extended by MTD.

This warranty gives you specific legal rights. You may also have other rights which vary from state to state.

WARNING TO PURCHASERS OF INTERNAL COMBUSTION ENGINE EQUIPPED MACHINERY OR DEVICES IN THE STATE OF CALIFORNIA

The equipment which you have just purchased does not have a spark arrester. If this equipment is used on any forest covered land, brush covered land, or grass covered unimproved land in the State of California, before using on such land, the California law requires that a spark arrester be provided. In addition, spark arrester is required by law to be in effective working order. The spark arrester must be attached to the exhaust system and comply with Section 4442 of the California Public Resources Code.

IMPORTANT

It is suggested that this manual be read in its entirety before attempting to assemble or operate. Keep this manual in a safe place for future reference and for ordering replacement parts.

This unit is shipped WITHOUT GASOLINE or OIL. After assembly, see operating section of this manual for proper fuel and amount.

Your rotary mower is a precision piece of power equipment, not a plaything. Therefore exercise extreme caution at all times.

SAFE OPERATION PRACTICES FOR RIDING VEHICLES

1. Know the controls and how to stop quickly—**READ THE OWNER'S MANUAL.**
2. Do not allow children to operate vehicle. Do not allow adults to operate it without proper instruction. Only persons well acquainted with these rules of safe operation should be allowed to use your mower.
3. Do not carry passengers.
4. Keep the area of operation clear of all persons, particularly small children and pets. Stop engine when they are in the vicinity of your mower. Although the area of operation should be completely cleared of foreign objects, a small object may have been overlooked and could be accidentally thrown by the mower in any direction.
5. Clear work area of objects which might be picked up and thrown by the mower in any direction.
6. Disengage all attachment clutches and shift into neutral before attempting to start engine.
7. Disengage power to attachment(s) and stop engine before leaving operator position.
8. Disengage power to attachment(s) and stop engine before making any repairs or adjustments. Disconnect the spark plug wire and keep the wire away from the plug to prevent accidental starting.
9. Before attempting to unclog the mower or discharge chute, stop the engine and be sure the blade(s) have stopped completely. Disconnect the spark plug wire and keep the wire away from the plug to prevent accidental starting.
10. Disengage power to attachment(s) when transporting or not in use.
11. Take all possible precautions when leaving vehicle unattended such as disengaging power-take-off, lowering attachments, shifting into neutral, setting parking brake, stopping engine and removing key.
12. Do not stop or start suddenly when going uphill or downhill. Mow up and down face of steep slopes; never across the face.
13. Reduce speed on slopes and in sharp turns to prevent tipping or loss of control. Exercise extreme caution when changing direction on slopes.
14. Stay alert for holes in terrain and other hidden hazards.
15. Use care when pulling loads or using heavy equipment.
 - A. Use only approved drawbar hitch points.
 - B. Limit loads to those you can safely control.
 - C. Do not turn sharply. Use care when backing.
- D. Use counterweight(s) or wheel weights when suggested in owner's manual.
16. Watch out for traffic when crossing or near roadways.
17. When using any attachments never direct discharge of material toward bystanders nor allow anyone near vehicle while in operation.
18. Handle gasoline with care—it is highly flammable.
 - A. Use approved gasoline container.
 - B. Never remove cap or add gasoline to a running or hot engine or fill fuel tank indoors. Wipe up spilled gasoline.
 - C. Open doors if engine is run in garage—exhaust fumes are dangerous. Do not run engine indoors.
19. Keep the vehicle and attachments in good operating condition, and keep safety devices in place. Use guards as instructed in owner's manual.
20. Keep all nuts, bolts, and screws tight to be sure the equipment is in safe working condition.
21. Never store the equipment with gasoline in the tank inside a building where fumes may reach an open flame or spark. Allow engine to cool before storing in any enclosure.
22. To reduce fire hazard keep engine free of grass, leaves or excessive grease.
23. The vehicle and attachments should be stopped and inspected for damage after striking a foreign object, and the damage should be repaired before restarting and operating the equipment.
24. Do not change the engine governor settings or overspeed the engine.
25. When using the vehicle with mower, proceed as follows:
 - (1) Mow only in daylight or in good artificial light.
 - (2) Never make a cutting height adjustment while engine is running if operator must dismount to do so.
 - (3) Shut the engine off and wait until the blade comes to a complete stop before removing the grass catcher.
 - (4) Check blade mounting bolts for proper tightness at frequent intervals.
26. Check grass catcher bags frequently for wear or deterioration. For safety protection replace only with new bag meeting original equipment specifications.
27. Look behind to make sure the area is clear before placing the transmission in reverse and backing up.

INDEX

Limited Warranty	2	Illustrated Parts for Drive System	22 & 24
Safe Operating Practices	3	Parts List for Drive System	23 & 25
Know Your Tractor	4	Illustrated Parts for Steering	26
Battery Information	5	Parts List for Steering	27
Attaching the Cutting Deck	7	Illustrated Parts for Deck Linkage	28
Controls and Preliminary Checks	8	Parts List for Deck Linkage	29
Operation	10	Illustrated Parts for Cutting Deck	30
Maintenance—Tractor	11	Parts List for Cutting Deck	31
Maintenance—Cutting Deck	17	Illustrated Parts for Transaxle	32
Troubleshooting	19	Parts List for Transaxle	33
Illustrated Parts for Body Panels	20	Electrical Diagram and Parts List	34
Parts List for Body Panels	21	Parts Ordering Information	Back Cover

KNOW YOUR TRACTOR

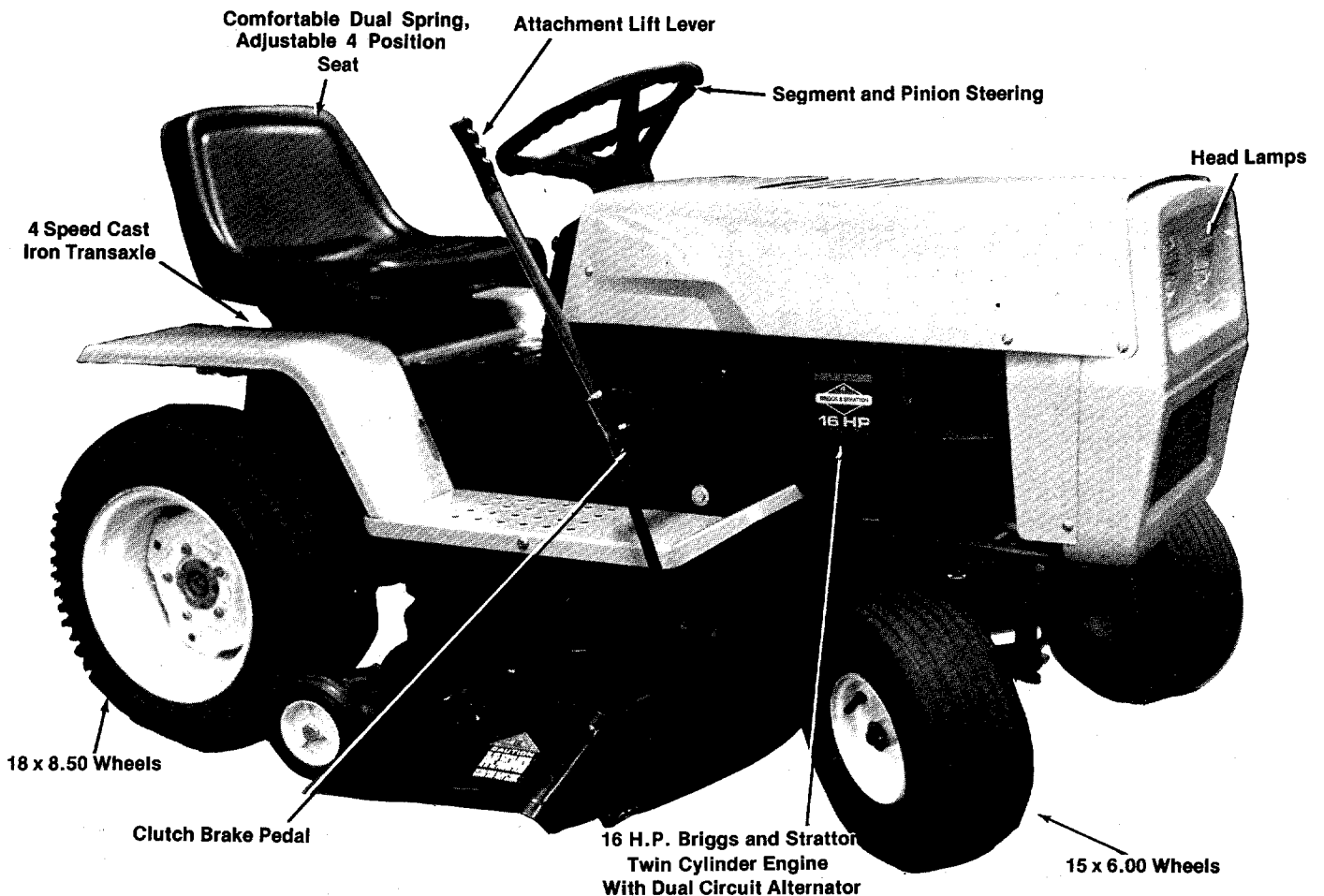

ASSEMBLY

The Garden Tractor is packed and shipped in one container and is fully assembled except for the steering wheel, seat, battery and mounting the cutting deck.

BATTERY INFORMATION



WARNING

- A. Battery acid must be handled with great care as it will blister the skin and damage clothing. It is advisable to wear goggles, rubber gloves, and a protective apron when working with it.
- B. Neutralize acid spilled on clothing with dilute ammonia water or a water solution of baking soda. If acid gets on clothes, dilute it with clean water first, then neutralize.
- C. If for any reason acid should be spattered in the eyes, wash it out immediately with clean cold water. Seek medical aid if discomfort continues.
- D. Since battery acid is corrosive to metals, do not pour into any sink or drain. Rinse empty electrolyte containers and mutilate before discarding.



DANGER

BATTERIES CONTAIN SULFURIC ACID AND MAY CONTAIN EXPLOSIVE GASES (when electrolyte has been added)

- A. Keep sparks, flame, cigarettes away.
- B. Hydrogen gas is generated during charging and discharging.
- C. Ventilate when charging or using in enclosed space.
- D. When using a charger—to avoid sparks, NEVER connect or disconnect charger clips to battery while charger is turned on.
- E. Always shield eyes, protect skin and clothing when working near batteries.

ACTIVATING THE BATTERY



NOTE

If the battery has been installed in the battery case at the factory, you only have to attach the negative (grounded) wire to the negative battery terminal with a hex head bolt $\frac{1}{4}$ x $\frac{3}{4}$ " lg., lockwasher and nut. Then proceed to attaching the seat assembly.

1. Place battery to be filled on bench or workbench. NEVER activate battery in unit. Remove vent caps from all cells.
2. Fill each cell carefully using battery grade 1.250-1.265 specific gravity. Sulfuric acid to be $\frac{3}{8}$ " above the top of the separators or to the split ring.
3. Allow battery to set for 20 minutes to $\frac{1}{2}$ hour. Add additional acid if necessary to bring it up to the proper level.
4. Replace the vent caps.
5. The battery can now be charged after the 20 minute setting period. Battery can be SLOW CHARGED (DO NOT FAST CHARGE) at a maximum bench rate of 4-5 amperes until the specific gravity reading is 1.265-1.275. A charging rate in excess of this will buckle and warp the positive plates and perforate the separators. If electrolyte bubbles violently while charging, reduce charging rate until excessive bubbling action subsides, then continue charging until specific gravity is reached.



CAUTION

After battery has been in service, add only approved water. DO NOT ADD ACID.



NOTE

See page 12 for battery maintenance information.

Installing the Battery



NOTE

The positive battery terminal is marked Pos. (+). The negative battery terminal is marked Neg. (-).

1. Place the battery in the battery box with the terminals towards the rear of the tractor.
2. Secure the battery with the two hold down rods, battery hold down, lockwashers and wing nuts. See figure 1.

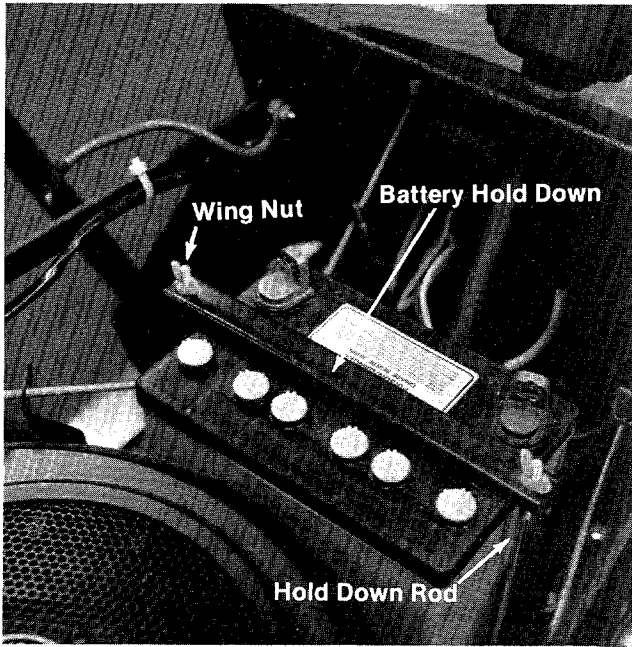

FIGURE 1

3. Attach the positive cable (from the starter solenoid) and the small wire (from the circuit breaker) to the positive battery terminal (+) with a 1/4-20 x 3/4" long bolt, lockwasher and hex nut.
4. Attach the negative cable (grounded) to the negative battery terminal (-) with the other 1/4-20 x 3/4" long bolt, lockwasher and hex nut.

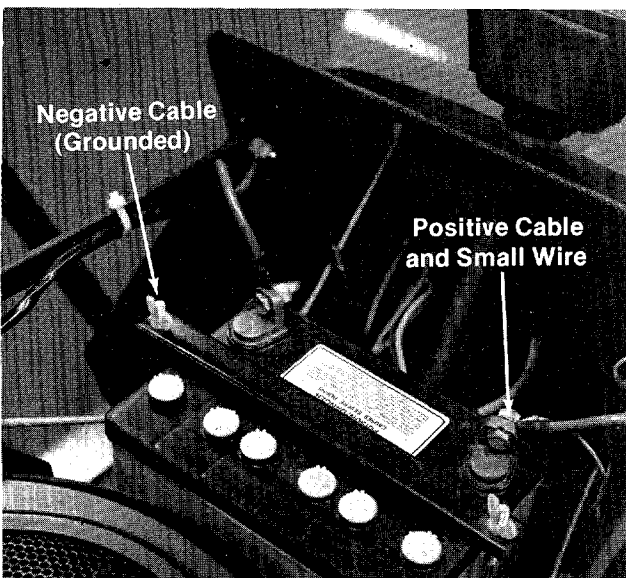

FIGURE 2



The vented battery allows any gases or liquid from the battery to be carried to the rear of the tractor and on to the ground.

SEAT ASSEMBLY

The seat can be adjusted to four positions. With the seat tipped forward, hook the front of the seat spring into the slots on the tractor frame. Allow the seat to pivot backwards until it rests on the rear of the springs. (See figure 3.)

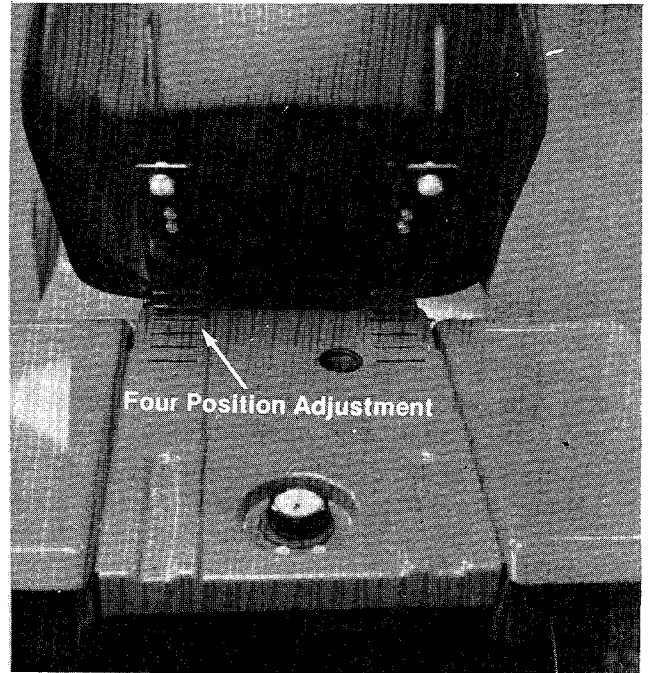

FIGURE 3
STEERING WHEEL

1. Place the steering wheel over the steering column extending through the dash. Line up the flats on the steering column with the flats in the steering wheel. (See figure 4.)

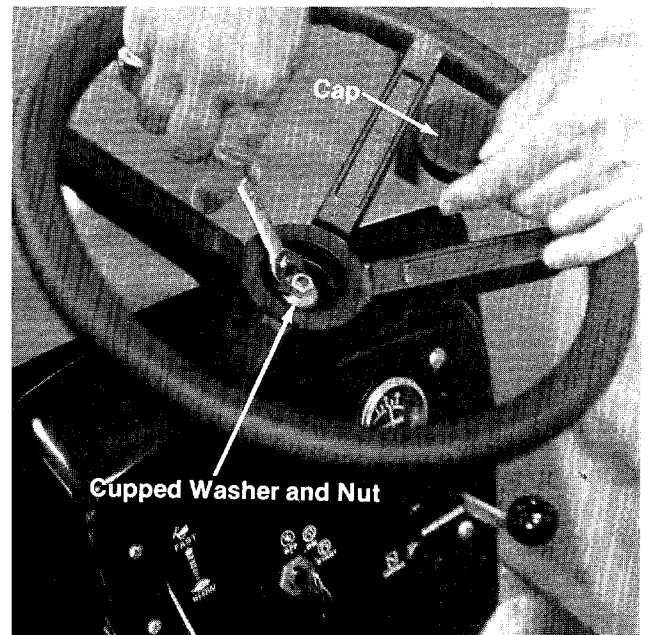

FIGURE 4

- Place the washer with the cupped side down over the steering column and secure with a hex nut 5/16".
- Place the cap over the center of the steering wheel and seat it with your hand.

TIRE PRESSURE

Reduce the rear wheel tire pressure to 15 p.s.i. for operation. The tires have been over-inflated for shipping. Equal tire pressure should be maintained on all tires. Maximum tire pressure is 30 p.s.i.

ATTACHING THE CUTTING DECK

Deck Assembly Screw Pack

- 4 Flat Washers 1/2" I.D
- 1 Small Cotter Hairpin
- 4 Medium Cotter Hairpins
- 2 Large Cotter Hairpins

- Remove the round belt keeper from the idler by removing the cotter hairpin. (See figure 5.)
- Unscrew the "L" bolt and swing the wire belt guard on the engine pulley forward.

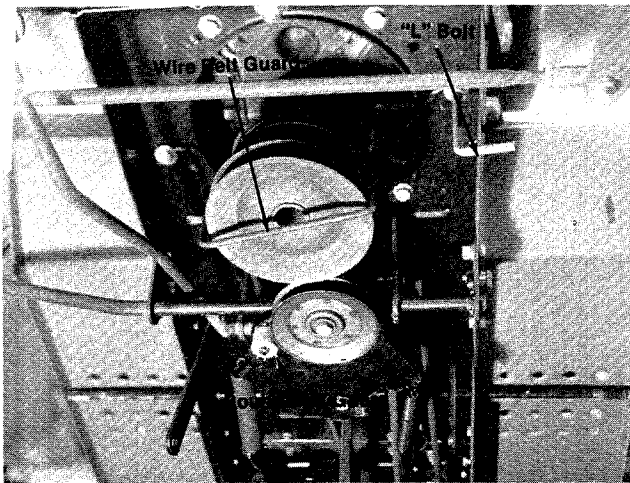

FIGURE 5.

- Adjust the deck wheels to their lowest cutting position.
- Move the tractor lift handle all the way back to the full raised position.
- Turn the tractor steering wheel all the way to the left.
- Slide the deck under the tractor from the left side.

- Attach the four tractor hanger brackets to the deck with four 1/2" I.D. washers and four medium cotter hairpins. (See figure 6.)



The left front tractor hanger bracket goes through the center of the V-belt.

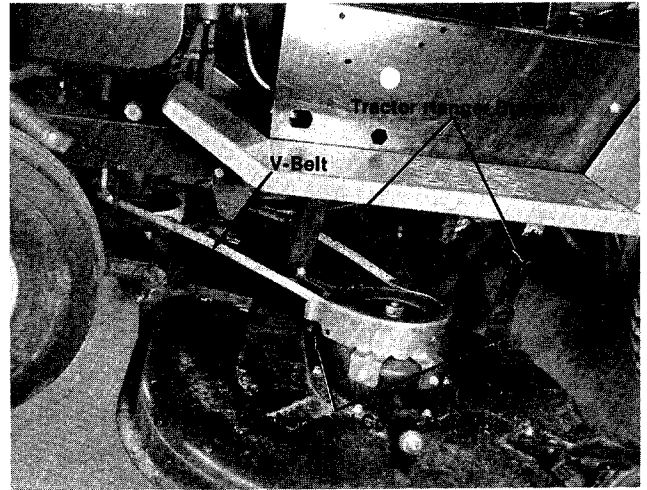

FIGURE 6

- Assemble the front cross bar as shown in figure 7 using two large cotter hairpins to attach the deck linkage to the tractor frame.

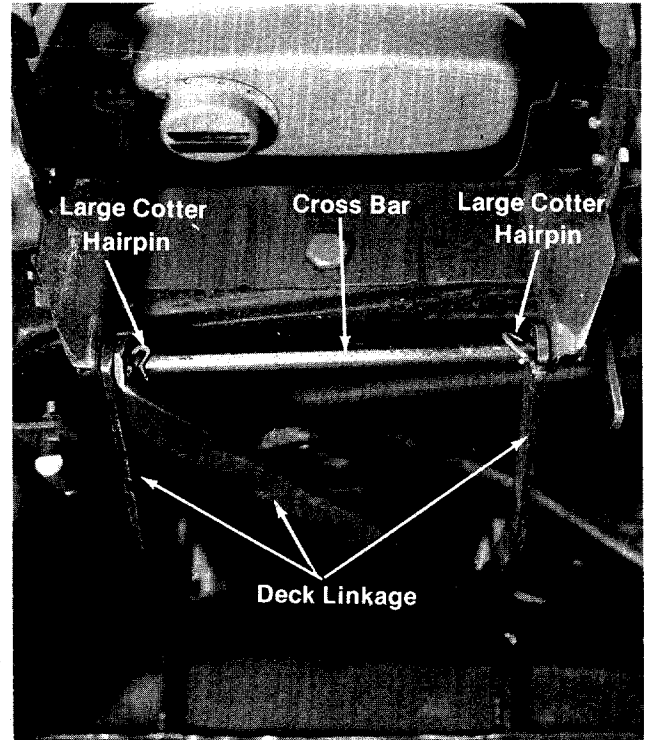

FIGURE 7

8. Place the deck belt around the engine pulley and idler. (See figure 8.)
9. Replace the round belt guard and swing the wire belt guard over the engine pulley and secure it with the "L" bolt.
10. Check all belt guards for clearance. The belt guards must be between 1/16" and 1/8" away from the belt when the PTO lever is in the engaged position.
11. Hook the brake release cable into the tractor idler bracket and secure it with the small cotter hairpin.

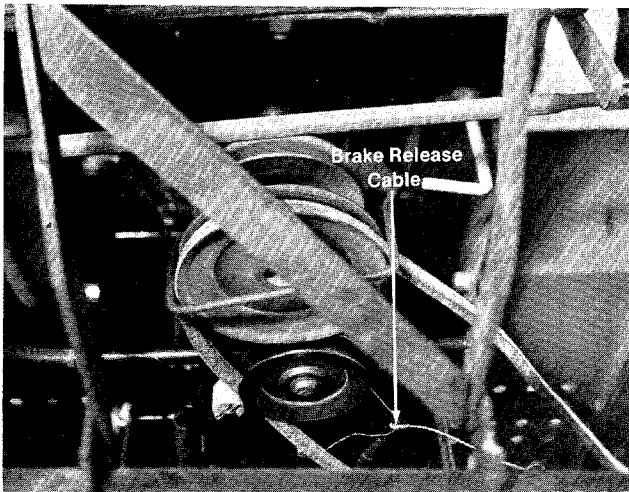

FIGURE 8

CONTROLS AND PRELIMINARY CHECKS

CONTROLS

Ignition Switch

The ignition switch is located in the center of the dashboard. Turn the key to the START position to start the engine. When the engine is running leave the key in the ON position. To stop the engine turn the key to the OFF position. (See figure 9.)



Remove the key from the tractor when the tractor is not in use to prevent accidental starting.

Throttle Control

The throttle control is located on the left side of the dashboard and is used to regulate the engine speed. (See figure 6.) The engine should be

operated from ¾ to full throttle (FAST) when operating any equipment that uses the tractor engine as a source of power such as the mowing deck, snow thrower or rotary tiller. (See figure 9.)

Choke Control

The choke control is located on the right side of the dashboard and is operated manually. Details for the choke operation are covered in the Engine Operating and Maintenance Instructions Manual. (See figure 9.)

Light Switch

The headlamps are operated by pushing the light switch located on the dashboard. The headlamps will only operate when the engine is running. (See figure 9.)

Ammeter

The ammeter registers the rate of battery charge or discharge. The ammeter should register on the plus (+) side when the engine is running in the FAST position until the battery is completely charged.

With a fully charged battery or with the engine idling the ammeter may not show a charge.

The maximum charging rate is 3 amps. The headlamps operate directly from the engine alternator and do not register on the ammeter. (See figure 9.)

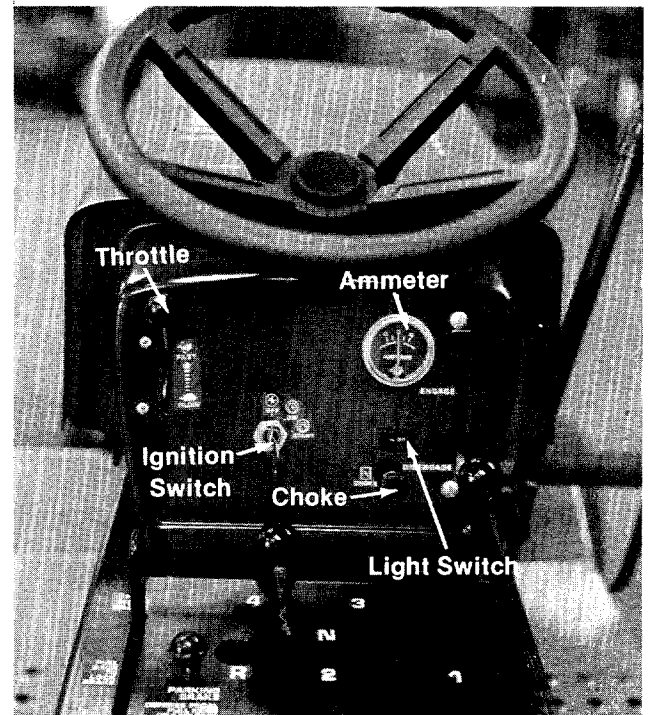

FIGURE 9

Gasoline Tank

The gasoline tank is located under the tractor seat. Fill the gasoline tank with approximately 1.9 gallons of clean, fresh, lead-free or leaded "regular" grade automotive gasoline. Tip the seat forward to fill the tank. (See figure 10.)

Seat Adjustment

The tractor seat is adjustable to four positions. To change positions, tip the seat all the way forward and lift it out of the slots on each side. (See figure 10.)

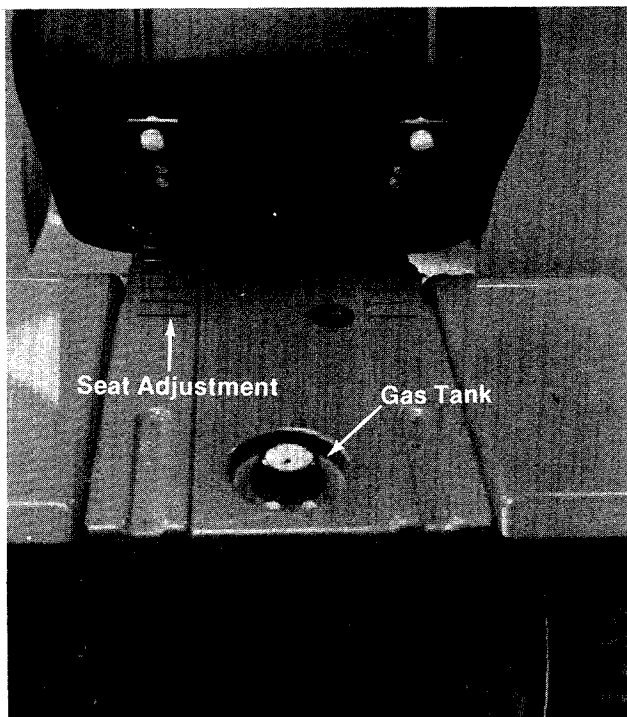

FIGURE 10

Gear Shift Lever

The transaxle has four forward gears, neutral and reverse. You do not shift through the gears on the transaxle as you would in an automobile. Pre-select the gear appropriate for the job you are doing. (See figure 10.)

You must depress the clutch-brake pedal and come to a complete stop before shifting gears. (See figure 11.)

Clutch-Brake Pedal

The clutch-brake pedal is located on the right side of the tractor. Depressing the clutch-brake pedal part way disengages the clutch. Pressing the pedal all the way down disengages the clutch and engages the disc brake.

NOTE

The clutch-brake pedal must be depressed to start the engine.

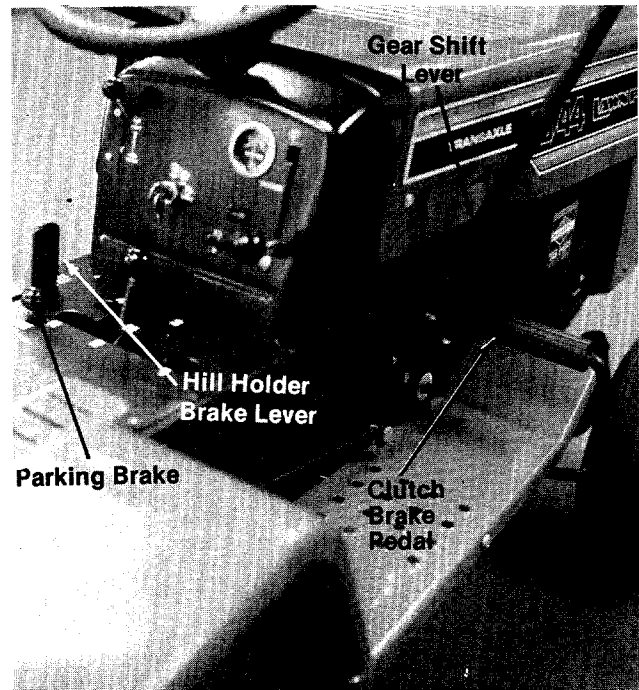

FIGURE 11

Parking Brake

To set the parking brake, depress the clutch-brake pedal and pull up the parking brake knob. It will stay in the raised position. To release the parking brake, depress and release the clutch-brake pedal. (See figure 11.)

Hill Hold Brake Lever

When stopping on a hill, hold the lever back while you release the clutch-brake pedal until the tractor begins to move, then release the lever. This prevents you from rolling down the hill while releasing the clutch. (See figure 11.)

Lift Lever

The five position lift lever is used to change the operating position of the attachments. To operate, pull the lever towards you. To release, move the lever to the right and then forward. (See figure 12.)

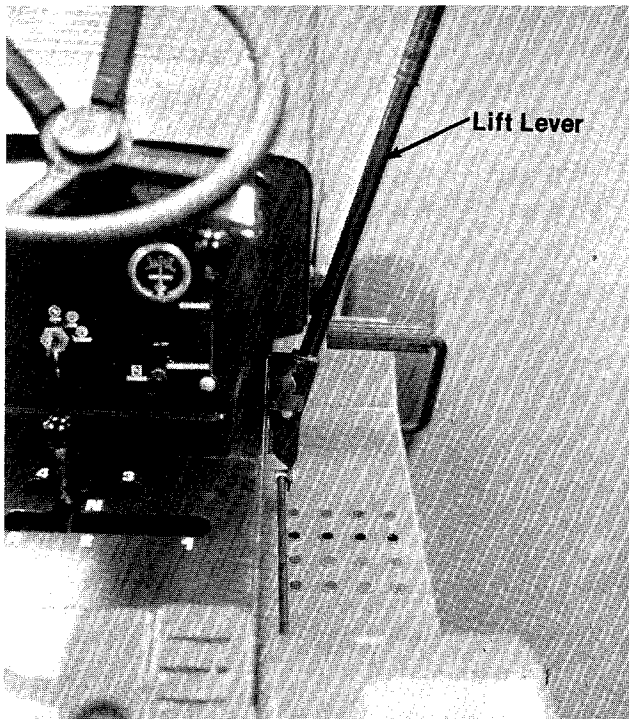

FIGURE 12

Power Take Off (PTO) Lever

The PTO lever is located on the right side of the dashboard. To engage the PTO, lift the lever slowly and lock it into the notch. (See figure 13.)



The PTO lever must be in the disengaged position (down) to start the engine.

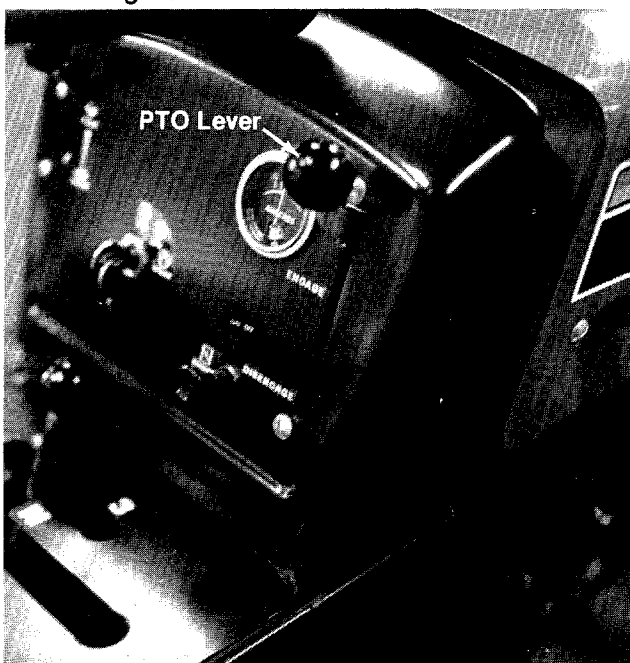

FIGURE 13

CHECKING OIL AND GASOLINE



When packaged for shipment, the machine contains no oil or gasoline. Before starting the engine, oil must be added to the engine crankcase and gasoline to the tank. **DO NOT** mix oil with gasoline.

Briggs & Stratton. Use a high quality detergent oil classified "For Service SC or SD or MS". Nothing should be added to the recommended oil.

Summer. (Above 40°F.) Use SAE 30. If not available use SAE 10W-30 or SAE 10W-40.

Winter. (Under 40°F.) Use SAE 5W-20 or SAE 5W-30. If not available, use SAE 10W or SAE 10W-30. Below 0°F., use SAE 10W or SAE 10W-30 diluted 10% with kerosene.

Place the engine level. Fill the oil sump to the **FULL** mark on the dipstick. Pour slowly.

Crankcase Capacity—3½ Pints.

OPERATION



1. Keep all shields and guards in place.
2. Before leaving operator's position:
Place gear shift lever in the neutral position.
Depress the clutch-brake and set the parking brake.
Place the PTO lever in the OFF position.
Shut off the engine.
Remove the ignition key.
3. Wait for all movement to stop, remove and ground the spark plug wire to the engine block before servicing the machine.
4. Keep people and pets a safe distance away from the machine.

Operation

1. Place the PTO lever in the disengaged (down) position.
2. Pull out the choke control. A warm engine requires less choking.
3. Set the throttle control in the FAST position.
4. Depress the clutch-brake pedal and hold it down.
5. Turn the ignition key to the START position. After the engine starts, release the key.
6. With the clutch-pedal depressed, move the gear shift lever into one of the forward gears.
7. Slowly release the clutch-brake pedal and the tractor will move forward.

8. When stopping, depress the clutch-brake pedal. This will apply both the clutch and the brake.
9. To shut off the engine, turn the ignition key to the left to the OFF position.

MAINTENANCE—Garden Tractor

TROUBLESHOOTING

Refer to the chart on page 19 for troubleshooting engine problems.

CRANKCASE OIL

To ensure maximum engine performance, perform the following periodic maintenance:

Oil Check

Check the oil level in the crankcase before each use of the machine and after every two hours of operation. Keep the oil level between ADD and FULL. See figure 14.

Oil Change

After the first two hours of operating a new engine, drain the oil (see figure 14) from the crankcase while engine is still hot and refill crankcase with new oil; thereafter change the oil after every 25 hours of operation. This procedure ensures for minimum wear of engine parts and provides for virtually trouble-free operation. To change the oil, proceed as follows:

- Step 1. Remove oil filler plug.
- Step 2. Drain the oil.
- Step 3. Replace oil filler plug.
- Step 4. Refill crankcase with oil. See page 10 for quantity and type of oil.



FIGURE 14

Steering Gears

Wipe off the old grease and dirt. After every 25 hours of operation place an automotive multi-purpose grease in the teeth of the segment and pinion gears. (See figure 13.)

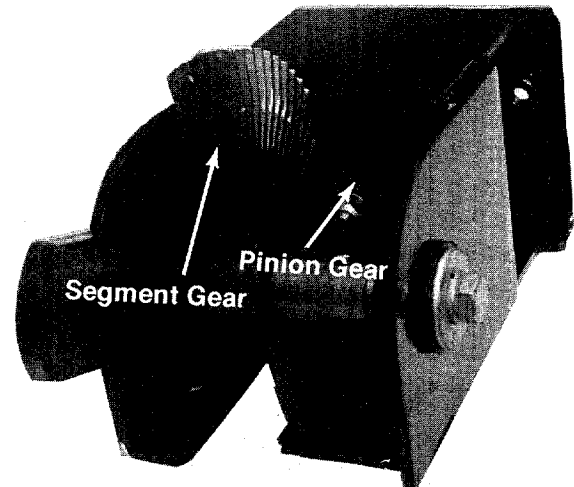

FIGURE 13

Transaxle

Check the oil level four times a year. Lubricant should be at the point of overflowing. Use E.P. 90 oil. Drain and refill every two years. Capacity 4 pints. (See figure 16.)

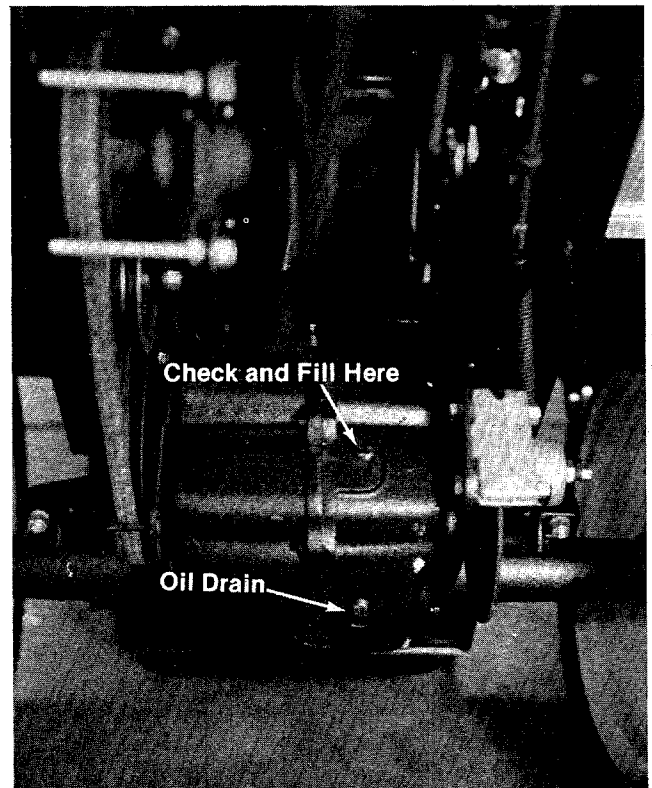

FIGURE 16

Linkage—Once a season lubricate all the pivot points on the clutch, brake and lift linkage with SAE 30 engine oil.

Wheel Bearings—The front wheel bearings and king pin bearings have Oilon PV 80 bearings that require no lubrication.

Ball Joints—The ball joints and drag link ends are permanently lubricated.

Battery Care and Handling

The use of distilled water is recommended. You may use drinking water unless the water has a high mineral content.

During freezing weather do not add water to the battery unless the tractor is going to be operated for a sufficient time to properly charge the battery.

Maintain the fluid level in the battery to the level indicated on the top of the battery. Keep the terminals clean and coated with grease.



WARNING

Whenever a battery is installed in a tractor, attach the positive cable first and then the negative (ground) cable.

When removing the battery, always disconnect the negative (ground) cable first.



NOTE

The fluid in the battery is corrosive; avoid spilling it. When performing maintenance on the machine, and battery is not in use, remove it to prevent inadvertent spilling.

Battery Storage

If your tractor is not to be used during an off season, the battery can be left in the tractor and **MUST** be stored in a charged condition. The specific gravity must read 1.265 or higher. Use a 12 volt, DC charger with a **MAXIMUM CHARGING RATE OF 5 AMPS**.



CAUTION

A discharged or partially discharged battery can freeze and crack causing extensive damage to the tractor.

During extreme cold weather, recharge the battery every 2 months or whenever the specific gravity is less than 1.200.

Charge the battery just prior to being put back into service.

Fuel Shut-Off Valve and Filter

The valve and filter is located on the bottom of the gasoline tank located at the extreme rear of the tractor.

Turn the valve knob in to shut off the fuel flow. Turn the valve knob out to operate the tractor. (See figure 17.)

The entire valve can be pulled out to clean the filter. When reassembling, place the rubber grommet into the gasoline tank first, then push the valve all the way in.



WARNING

Only use factory approved parts if repairs are needed on the gasoline tank, grommet, valve or gasoline line.

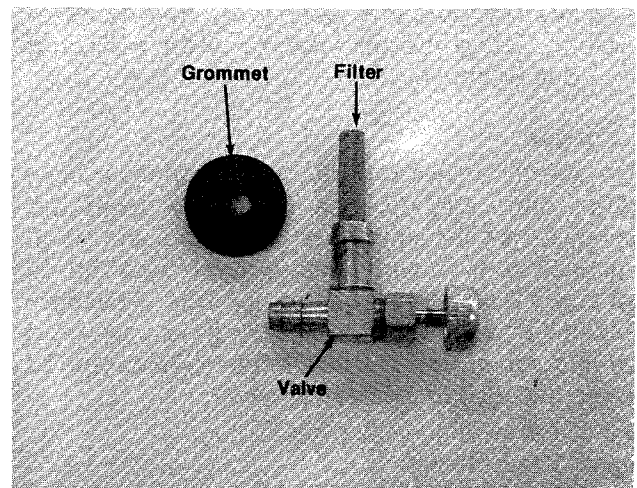

FIGURE 17

Installation of Tire to Rim



WARNING

The following procedure must be followed when removing or installing a tire to the rim.

1. Lubricate the tire beads and rim flanges.
2. Do not exceed 30 p.s.i. when seating beads.
3. Adjust to recommended pressure after beads are sealed.

Rear Wheel Tract Adjustment

The distance between the rear wheels can be changed from wide to narrow by removing the rear wheels one at a time and reversing them on the hub.

With the rear wheels in the narrow position, their outside is even with the outside of the front wheels.

With the rear wheels in the wide position their inside is even with the inside of the front wheels.

Wheel Alignment

The front wheels should toe-in approximately 1/8".

Measure the distances A and B on the front wheels. (See figure 18.)



Dimension B should be approximately 1/8 inch less than dimension A.

To adjust the toe-in, loosen the hex jam nut, remove the elastic locknut, lift the tie rod end out of the hole in the steering arm and screw the tie rod end in or out as necessary. (See figure 19.)

Reassemble the tie rod end after the correct alignment is made.

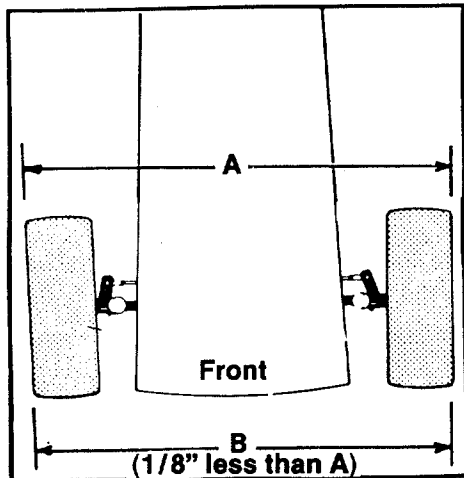

FIGURE 18

Drag Link

If the drag link or ball joints are changed the new assembly must be adjusted to the exact same length as the original. If adjusted wrong it will allow the tractor to turn sharper one direction than the other.

To take off the drag link, remove the nuts and lockwashers holding the ball joint to the steering gear and left front axle bracket.

Brake Adjustment



CAUTION

Do not adjust the brake while the engine is running. Be sure to block the wheels of the tractor before making the brake adjustment.

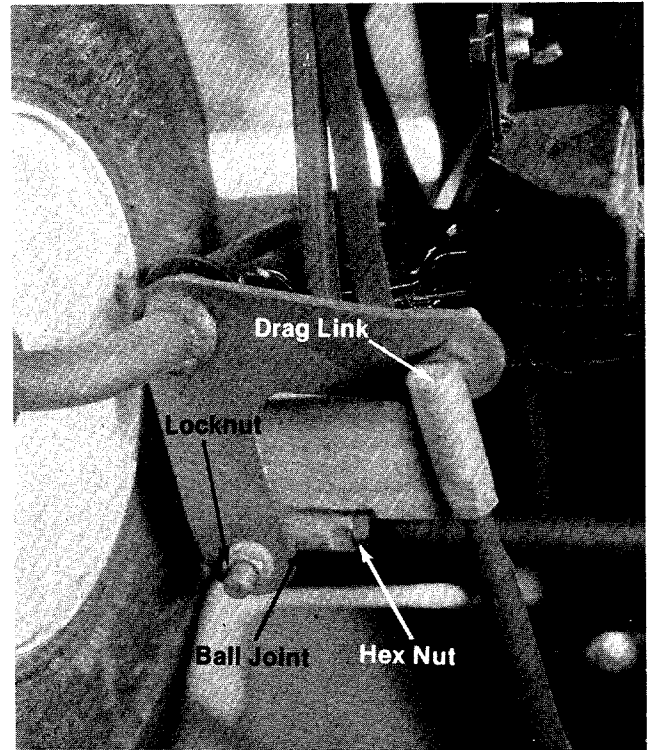

FIGURE 19

1. Loosen the locknut. (See figure 20.)
2. Tighten the center bolt all the way in.
3. Unscrew the center bolt one complete turn.
4. Test the brakes and repeat step three if necessary.
5. Tighten the locknut.

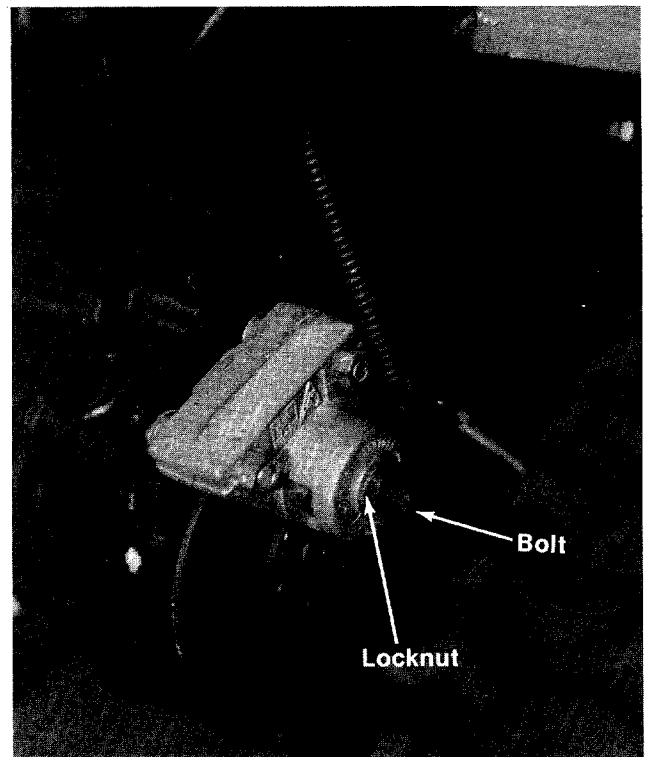

FIGURE 20

Changing the Front Drive Belt

1. Remove the cutting deck and battery.
2. Raise and block the front wheels of the tractor so you can work under it.
3. Unscrew the belt guard release next to the engine pulley. (See figure 21.)

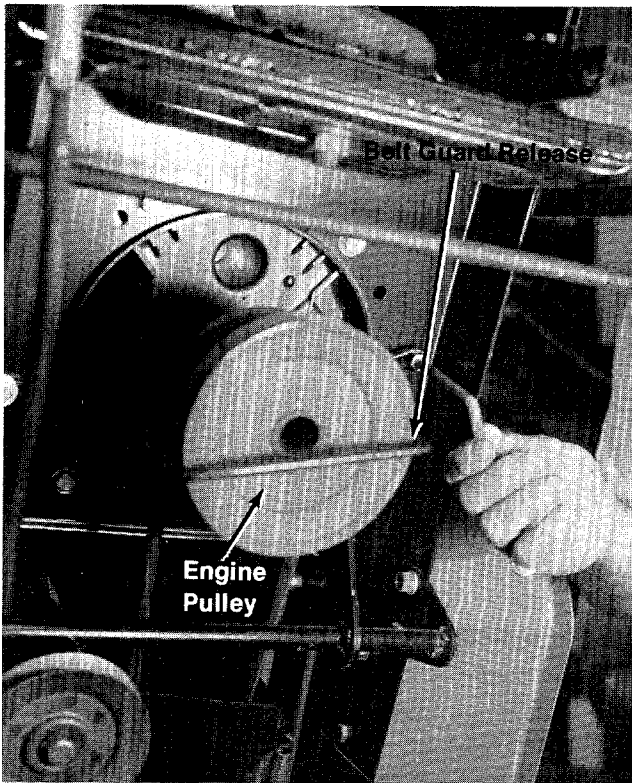

FIGURE 21

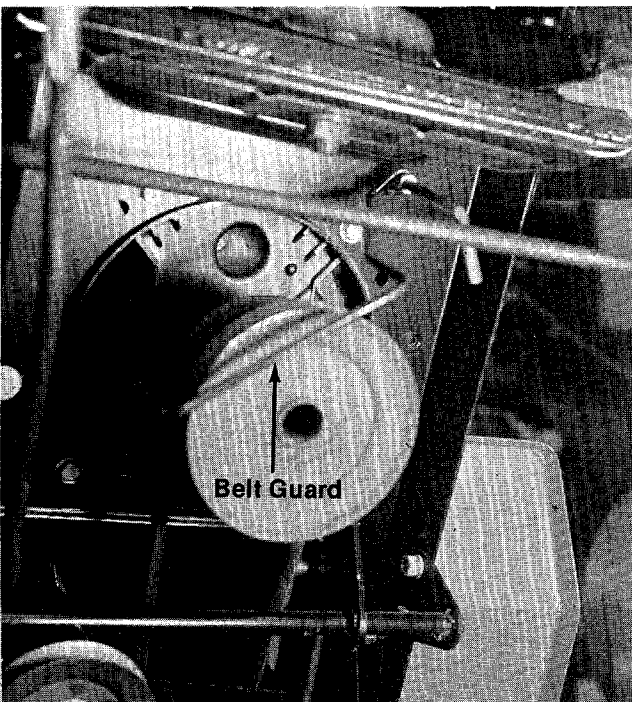

FIGURE 22

4. Swing the belt guard forward towards the front of the tractor. (See figure 22.)



Observe the way the belt is twisted. If the new belt is installed backwards, the tractor will run backwards.

5. Using a bar or large screw driver, pry the pulley assembly towards the front of the tractor and unhook the belt from the pulley. (See figure 23.)
6. Install the new belt by hooking it over the engine pulley and twisting the belt to the left as you attach it to the pulley.
7. Test the operation of the tractor to assure the belt has been installed correctly.

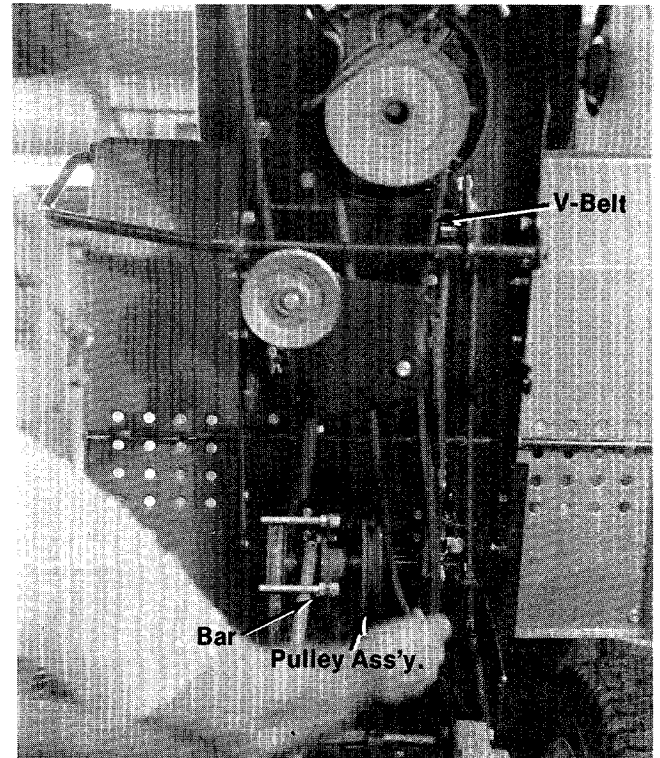

FIGURE 23

Removing the Rear (Clutch) Belt

1. Remove the cutting deck and battery.
2. Raise and block the front wheels of the tractor so you can work under it.
3. Depress the clutch-brake pedal and set the parking brake.
4. Remove the two belt guard pins on the pulley assembly. (See figure 24.)

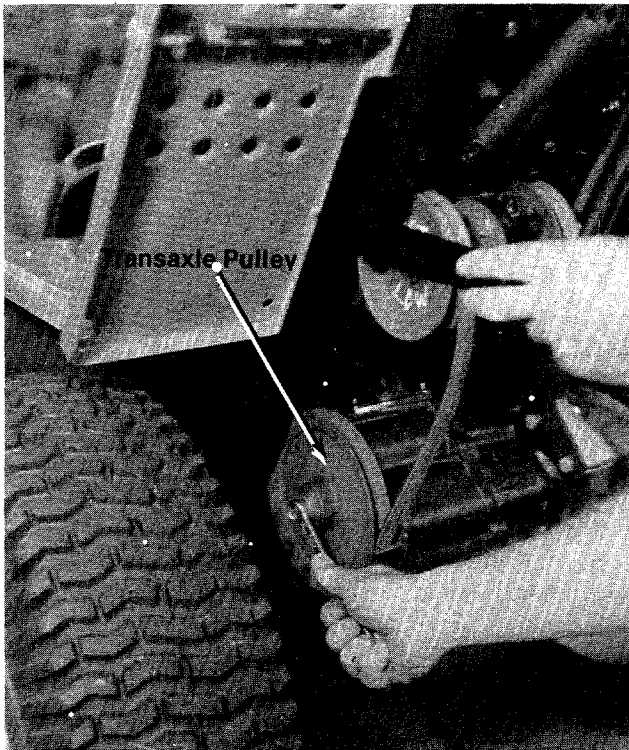

FIGURE 24

5. Take off the idler assembly by removing the center bolt.



NOTE

Be sure the belt clip is reassembled the same way. (See figure 25.)

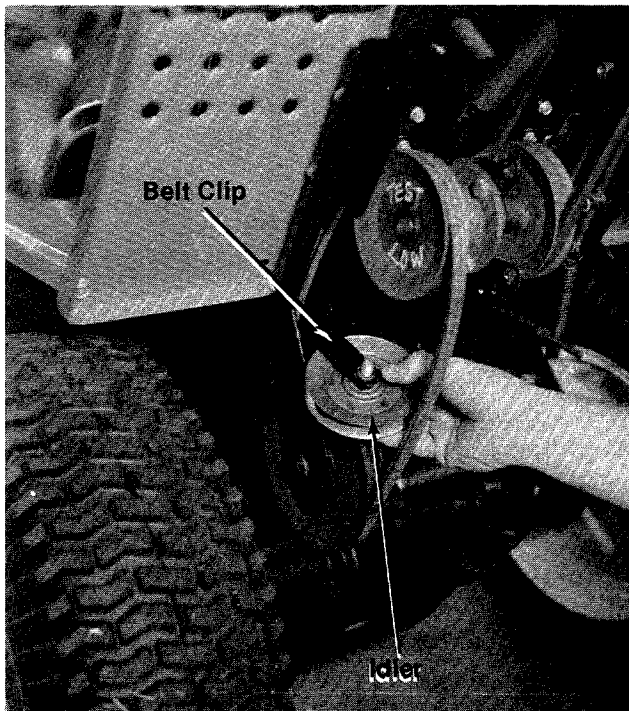

FIGURE 25

6. Remove the center bolt and slide the transaxle pulley off. (See figure 26.)
7. Reassemble in reverse order with a new V-belt.

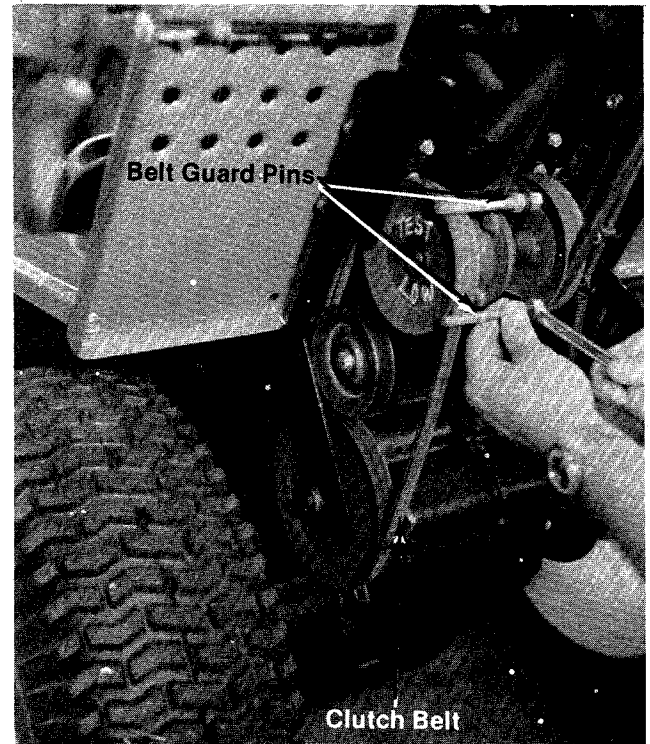

FIGURE 26

Off-Season Storage

If the machine is to be inoperative for a period longer than 30 days, the following procedures are recommended:

1. Working outdoors, drain all fuel from the fuel tank. Use a clean dry cloth to absorb the small amount of fuel remaining in the tank, then run the engine until all fuel in the carburetor is exhausted.
2. Drain all the oil from the crankcase (this should be done after the engine has been operated and is still warm) and refill the crankcase with clean new oil.
3. Disconnect the spark plug wires and remove the spark plugs from the cylinders. Pour about 2 or 3 tablespoons of engine oil into each cylinder, and then turn the engine over several times to spread out the oil. Replace the spark plugs but do not connect the wires.
4. Clean the engine and the entire tractor thoroughly.
5. Lubricate all lubrication points and wipe the entire machine with an oiled rag in order to protect the surfaces.
6. Battery storage. See page 12.

Clean Air Cleaner

Clean and re-oil foam pre-cleaner at 3 month intervals or very 25 hours, whichever occurs first.

1. Remove the wing nut and cover.
2. Remove the hex nut and washer with a 7/16" wrench and lift off the inner oblong cover.
3. Remove the foam pre-cleaner element by sliding it off the paper filter cartridge.
 - A. Wash foam in liquid detergent and water.
 - B. Squeeze dry.
 - C. Oil with one ounce of engine oil. Squeeze to distribute oil evenly. Remove excess oil.
4. Install foam element over the paper filter cartridge. Install the oblong inner cover and secure with the hex nut. Replace the outer cover and secure with the wing nut.

Yearly or every 100 hours, whichever occurs first, remove paper air filter cartridge. Clean by tapping gently on flat surface. If very dirty, replace cartridge, or wash in liquid detergent and water. Rinse until water remains clear. Cartridge must be air dried thoroughly before re-using. (See figure 27.)

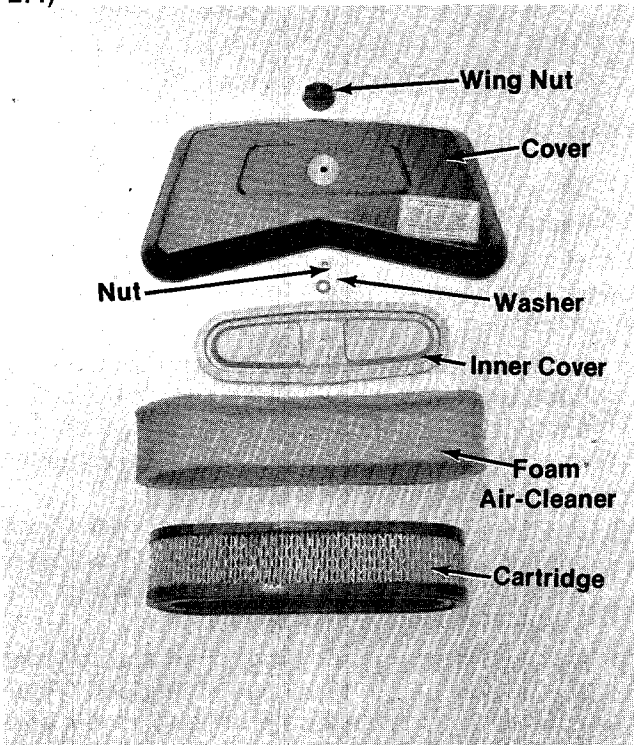

FIGURE 27

Clean Cooling System

Grass or chaff may clog cooling system after prolonged service. Continued operation with a clogged cooling system causes severe overheating and possible engine damage. Remove blower housing and clean regularly. (See figure 28.)

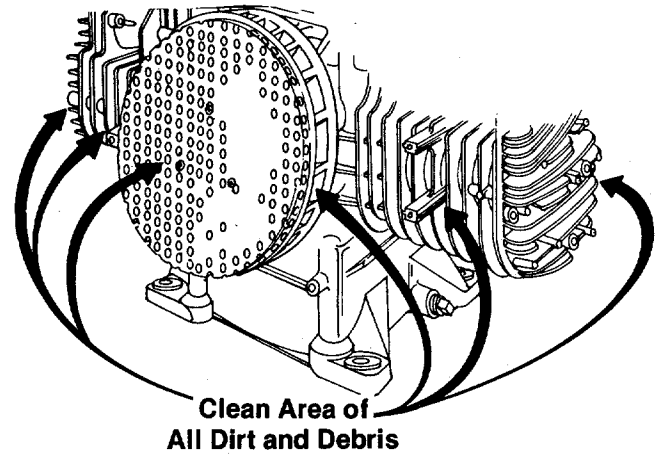

FIGURE 28

Carburetor Adjustments

Minor carburetor adjustments may be required to compensate for differences in fuel, temperature, altitude and load.

To Adjust Carburetor—Turn needle valve clockwise until it just closes.



CAUTION

Valve may be damaged by turning it in too far.

Now open needle valve 1½ turns counterclockwise. Close idle valve in same manner and open 1½ turns. This initial adjustment will permit the engine to be started and warmed up prior to final adjustment. (See figure 29.)

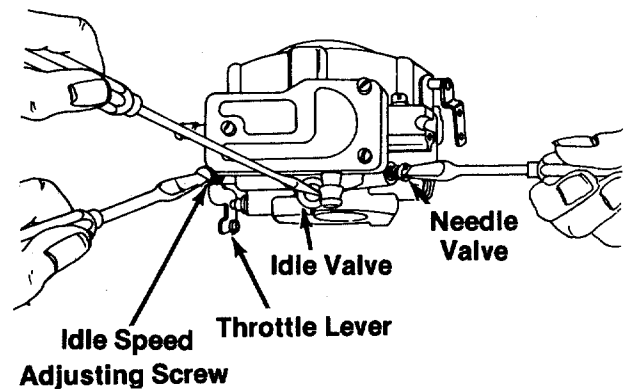

FIGURE 29

Final Adjustment

Place governor speed control lever in "IDLE" position. Hold throttle lever against idle stop and set idle speed adjusting screw to obtain 1400 R.P.M. Turn idle valve slowly clockwise (lean mixture) until engine misses or R.P.M. slows. Then turn idle valve ½ turn counterclockwise.

Hold throttle shaft in closed position and adjust idle speed screw to 900 R.P.M. Release the throttle. With remote control in idle position, adjust tab "A" to obtain 1400 R.P.M.

NOTE

Governed idle must be adjusted on all engines for proper operation. The smaller spring keeps the engine on governor, even at idle speed. If moderate loads are applied at idle, the engine will not stall. Idle speed should be no lower than 11 R.P.M.

Place governor speed control lever in fast position. Then turn needle valve in slowly clockwise (lean) until engine misses or R.P.M. slows. Then turn needle valve 1/2 turn counterclockwise.

If engine does not accelerate properly, readjust needle valve approximately 1/8 turn counterclockwise (richer). (See figure 30.)

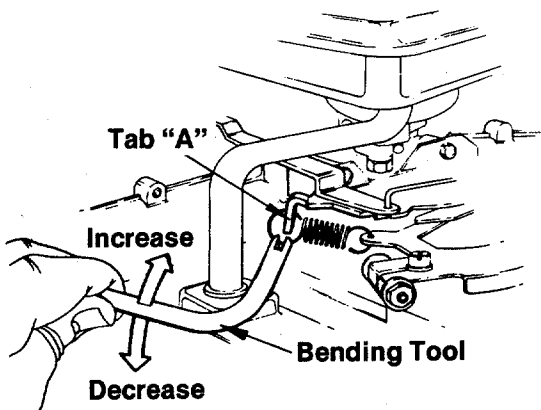

FIGURE 30

MAINTENANCE CUTTING DECK

Lubrication

The blade spindles on the cutting deck are permanently lubricated.

Cutting Blade

The blades may be removed for sharpening or replacement as follows:

1. Remove the large bolt and lockwasher holding the blade and adapter to the blade spindle.
2. Remove the blade and adapter from the crankshaft.
3. Remove the two smaller bolts, lockwashers and nuts holding the blade to the adapter. (See figure 31.)

When sharpening the blade, follow the original angle of grind as a guide. It is extremely important that each cutting edge be ground equally to prevent an unbalanced blade. An unbalanced blade will cause excessive vibration when rotating at high speeds and may cause damage to the mower.

The blade can be tested for balance by balancing it on a screwdriver. Remove metal from the heavy side until it balances evenly. (See figure 32.)

NOTE

When replacing the blade, be sure the side of the blade marked "Bottom" or having the part number, is facing down toward the ground when the mower is in the operating position.

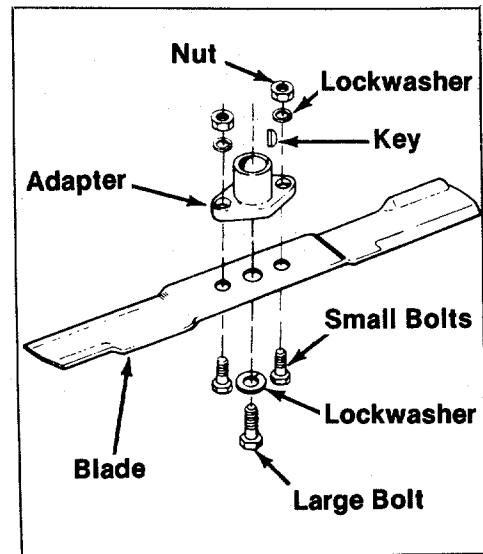

FIGURE 31.

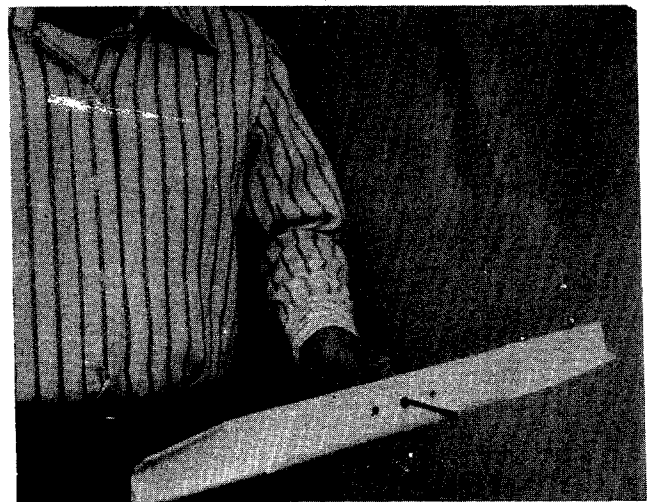

FIGURE 32

Removing the Deck Belt

1. Remove the two hex screws holding the belt guard to the timing belt cover. (See figure 33.)
2. Replace the belt and reassemble.

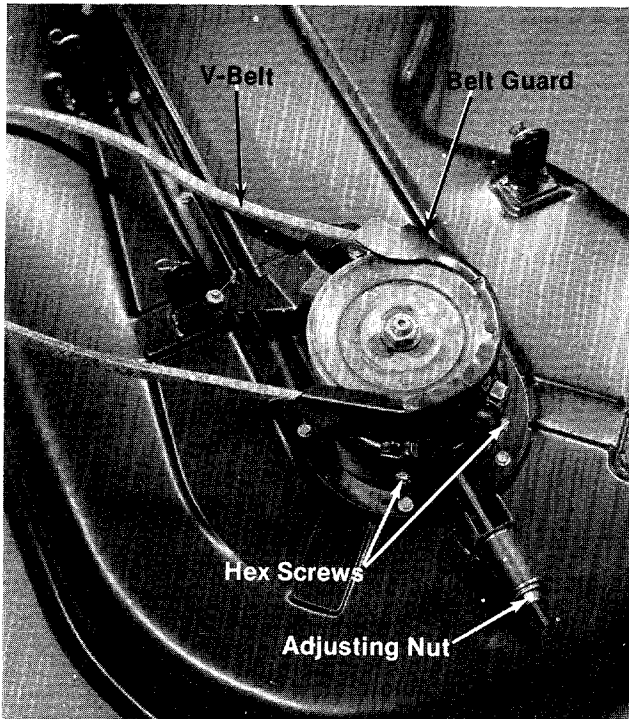

FIGURE 33

Removing the Blade Belt

1. Remove the belt guard and drive pulley. (See figure 33.)
2. Remove the blade belt cover.
3. Loosen the four hub bolts. (See figure 36.)
4. Loosen the tension adjusting nut. (See figure 34.)
5. Remove and replace the blade belt.
6. Reassemble and adjust the belt tension. (See figure 36.)

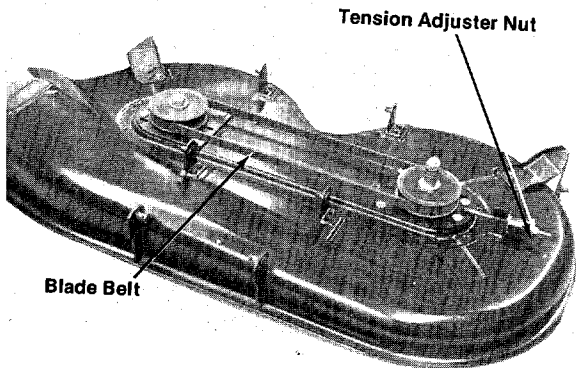

FIGURE 34

Timing the Blades

1. Remove the center blade bolt on either blade.

2. Rotate the blade on the cutting deck and reassemble the other blade at 90° exactly as shown in figure 35.



If the blades are not timed it will affect the cut of the grass and the discharge.

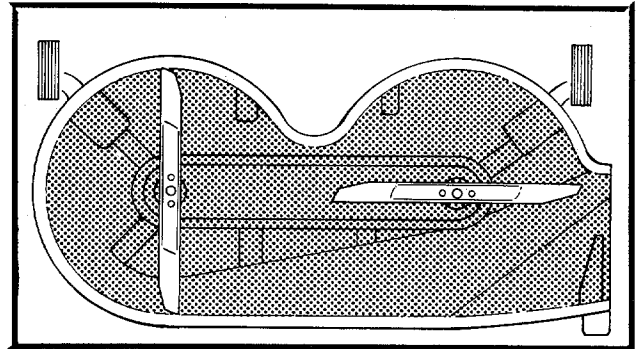

FIGURE 35.

Adjusting the Belt Tension

1. Loosen the four spindle nuts on the bottom of the cutting deck. (See figure 36.)
2. Tap the deck with a hammer handle to loosen the washers on the four spindle nuts.
3. Tighten the four spindle nuts.

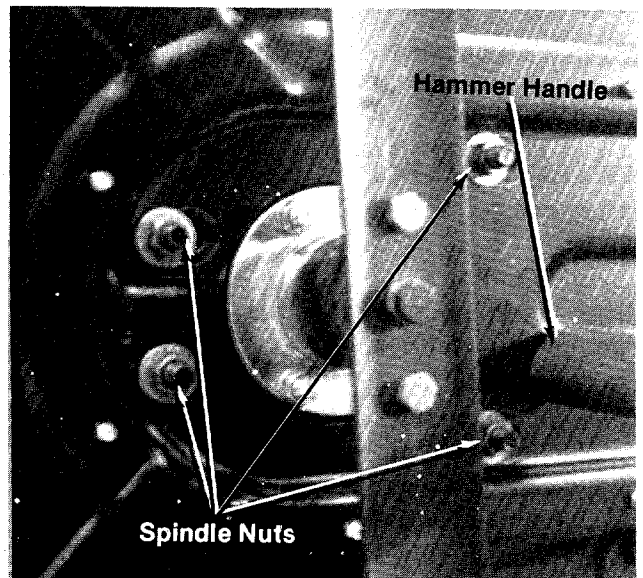

FIGURE 36



This instruction manual covers various models and all specifications shown do not necessarily apply to your model. Specifications subject to change without notice or obligation.

Trouble Shooting Chart

Problem	Cause	Remedy
1 Engine fails to start	A Check fuel tank for gas	A Fill tank if empty
	B Spark plug lead wire disconnected	
	C Throttle control lever not in the starting position	C Move throttle lever to start position.
	D Faulty spark plug (if either plug fails to fire, the engine will not start)	D Spark should jump gap between control electrode and side electrode. If spark does not jump, replace the spark plug.
	E Carburetor improperly adjusted. Engine flooded.	E Remove spark plug, dry the plug, crank engine with plug removed, and throttle in off position. Replace spark plug and lead wire and resume starting procedures.
	F Old stale gasoline	F Drain and refill with fresh gasoline.
2 Hard starting or loss of power	A Spark plug wire loose	A Connect and tighten spark plug wire.
	B Carburetor improperly adjusted	B Adjust carburetor. See engine section of this manual.
	C Dirty air cleaner	C Clean air cleaner as described in the engine section of this manual.
3 Operation erratic	A Dirt in gas tank	A Remove the dirt and fill tank with fresh gas
	B Dirty air cleaner	B Clean air cleaner as described in the engine section of this manual
	C Water in fuel supply	C Drain contaminated fuel and fill tank with fresh gas.
	D Vent in gas cap plugged	D Clear vent or replace gas cap
	E Carburetor improperly adjusted	E Adjust carburetor. See engine section of this manual.
4 Occasional skip (hesitates) at high speed	A Carburetor idle speed too slow	A Adjust carburetor. See engine section of this manual.
	B Spark plug gap too close	B Adjust to .030"
	C Carburetor idle mixture adjustment improperly set	C Adjust carburetor. See engine section of this manual.
5 Idles poorly	A Spark plug fouled, faulty, or gap too wide.	A Reset gap to .030" or replace spark plug
	B Carburetor improperly adjusted	B Adjust carburetor. See engine section of this manual.
	C Dirty air cleaner	C Clean air cleaner as described in the engine section of this manual.
6 Engine overheats	A Carburetor not adjusted properly	A Adjust carburetor. See engine section of this manual.
	B Air flow restricted	B Remove blower housing and clean as described in the engine section of this manual.
	C Engine oil level low	C Fill crankcase with the proper oil
7 Excessive vibration	A Cutter blade loose or unbalanced	A Tighten blade and adapter. Balance blade.

NOTE: For repairs beyond the minor adjustments listed above, please contact your local service dealer.

149-820A

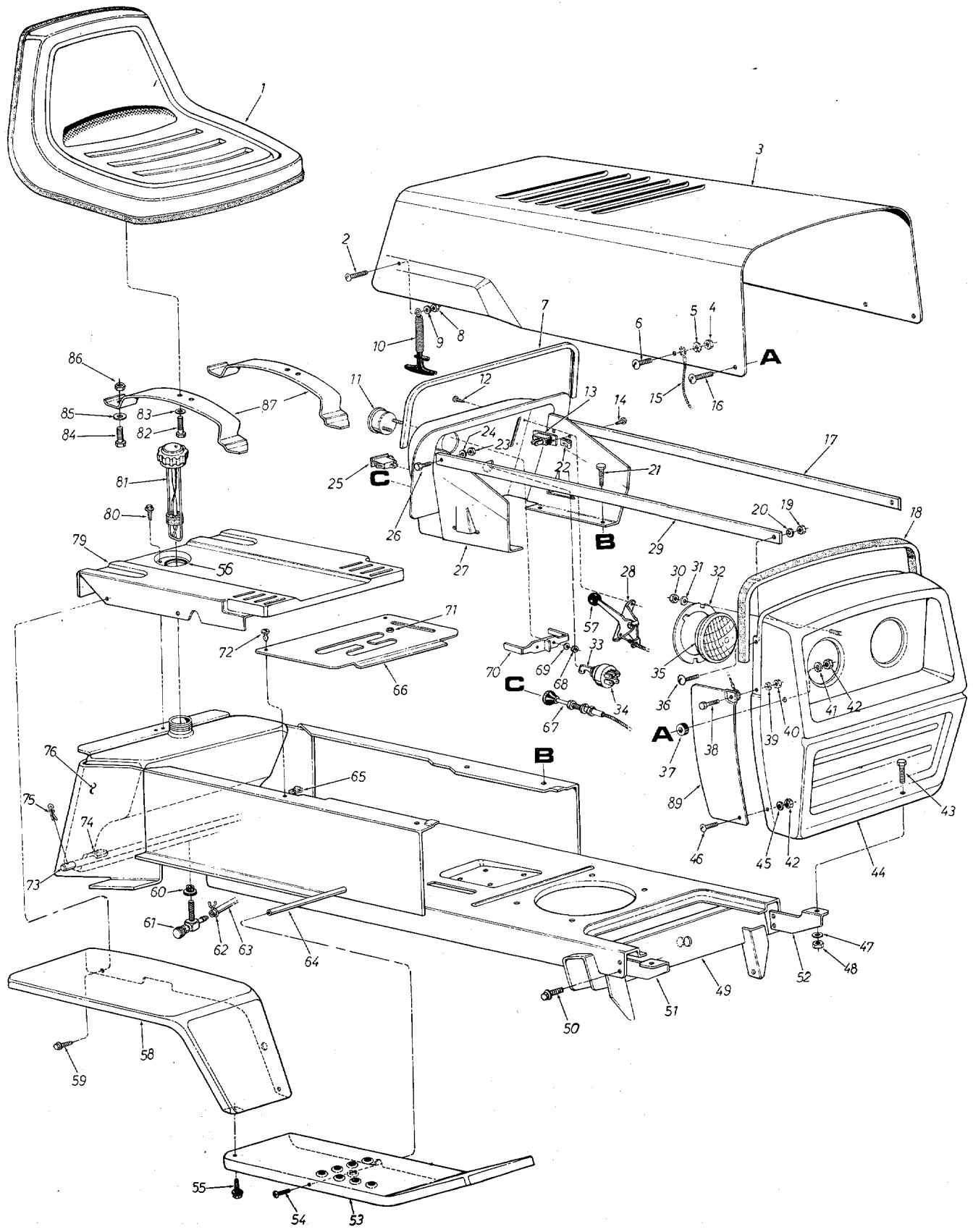

BODY PANELS

PARTS LIST FOR MODEL 149-820A

REF. NO.	PART NO.	COLOR CODE	DESCRIPTION	NEW PART	REF. NO.	PART NO.	COLOR CODE	DESCRIPTION	NEW PART
1	757-0286		Seat Assembly	N	47	736-0119		L-Wash. 5/16" Scr.*	
2	710-0286		Truss Mach. Scr. 1/4-20 x .50" Lg.*		48	712-0267		Hex Nut 5/16-18 Thd.*	
					49	13820		Lower Frame Ass'y.	N
3	13808	-462	Hood	N	50	710-0600		Hex Thd. Rolling Scr. 5/16-24 x .50" Lg.	
4	712-0287		Hex Nut 1/4-20 Thd.*		51	13862		Grille Mount Brkt.—R.H.	N
5	736-0329		L-Wash. 1/4" Scr.*		52	13863		Grille Mount Brkt.—L.H.	N
6	710-0286		Truss Mach. Scr. 1/4-20 x .50" Lg.*		53	13828	-452	Running Board—R.H.	N
						13827	-452	Running Board—L.H. (Not Shown)	N
7	731-0423		Vinyl Molding Strip	N					
8	712-0287		Hex Nut 1/4-20 Thd.*		54	710-0323		Truss Mach. Scr. 5/16-18 x .75" Lg.*	
9	736-0329		L-Wash. 1/4 Scr.*		55	710-0600		Hex Thd. Rolling Scr. 5/16-24 x .50" Lg.	
10	723-0296		Hood Latch Ass'y.		56	735-0179		Grommet (Gas Tank Neck)	N
11	725-0119		Ammeter		57	720-0166		Knob (Throttle Control)	
12	710-0351		Hex Tap Scr. #10 x .50" Lg.*		58	13810	-462	Fender Ass'y.—R.H.	N
13	725-0459		Circuit Breaker 8 Amp.			13809	-462	Fender Ass'y.—L.H. (Not Shown)	N
14	710-0351		Hex Tap Scr. #10 x .50" Lg.*		59	710-0600		Hex Thd. Rolling Scr. 5/16-24 x .50" Lg.	
15	727-0199		Hood Stop		60	735-0149		Bushing (Gas Tank)	
16	710-0255		Truss Mach. Scr. 1/4-20 x .75" Lg.*		61	751-0171		Fuel Shut-Off Valve	
17	13807		Grille Positioning Rod	N	62	726-0183		Hose Clamp 3/8"	
18	722-0137		PVC Foam Strip 1/2 x 1.00" x 12.5" Lg.	N	63	751-0173		Gas Line 60" Lg.	N
19	712-0287		Hex Nut 1/4-20 Thd.*		64	738-0435		Running Board Rod	N
20	736-0329		L-Wash. 1/4" Scr.*		65	—		Part of Ref. No. 72	
21	710-0599		Hex Thd. Rolling Scr. 1/4-20 x .50" Lg.		66	13834	-452	Transmission Cover	N
					67	746-0343		Choke Control Comp.	
22	712-0344		Speed Nut #10 Z		68	—		Part of Ref. No. 11	
23	712-0287		Hex Nut 1/4-20 Thd.*		69	—		Part of Ref. No. 11	
24	736-0329		L-Wash. 1/4" Scr.*		70	—		Part of Ref. No. 11	
25	725-0634		Light Switch	N	71	731-0405		Snap Bushing	
26	710-0258		Hex Scr. 1/4-20 x .62" Lg.*		72	726-0167		1/4-Turn Stud	
27	13843		Dash Panel Ass'y.	N	73	738-0401		Hitch Rod	
28	746-0354		Throttle Control Comp.	N	74	722-0135		P.V.C. Foamstrip 1/2" x 1.00" x 2.00"	
29	13807		Grille Positioning Rod	N	75	714-0149		Internal Cotter Pin	
30	712-0287		Hex Nut 1/4-20 Thd.*		76	751-0259		Gas Tank	N
31	736-0329		L-Wash. 1/4 Scr.*		79	13814		Seat Plate	N
32	09960		Head Lamp Retainer		80	710-0600		Hex Thd. Rolling Scr. 5/16-24 x .50" Lg.	
33	725-0201		Ignition Key		81	723-0346		Gas Gauge	N
34	725-0267		Ignition Switch		82	710-0118		Hex Scr. 5/16-18 x .75" Lg.*	
35	725-0222		Head Lamp		83	736-0119		L-Wash. 5/16" Scr.*	
36	710-0258		Hex Scr. 1/4-20 x .62" Lg.*		84	710-0689		Hex Scr. Nylon Scr. 1/2-13 x .75" Lg.	
37	735-0126		Rubber Wash. .330 I.D. x .87 O.D. x .32 Thk.		85	736-0192		FI-Wash. .50" I.D. x 1.00" O.D. x .090	
38	710-0286		Truss Mach. Scr. 1/4-20 x .50" Lg.*		86	712-0206		Hex Nut 1/2-13 Thd.*	
39	736-0329		L-Wash. 1/4" Scr.*		87	13123		Seat Spring	
40	712-0287		Hex Nut 1/4-20 Thd.*		89	13864	-462	Grille Side Panel—R.H.	N
41	736-0329		L-Wash. 1/4" Scr.*			13235	-462	Grille Side Panel—L.H. (Not Shown)	
42	712-0287		Hex Nut 1/4-20 Thd.*						
43	710-0118		Hex Scr. 5/16-18 x .75" Lg.*						
44	13801	-462	Grille Ass'y.	N					
45	736-0329		L-Wash. 1/4" Scr.*						
46	710-0286		Truss Mach. Scr. 1/4-20 x .50" Lg.*						

149-820A

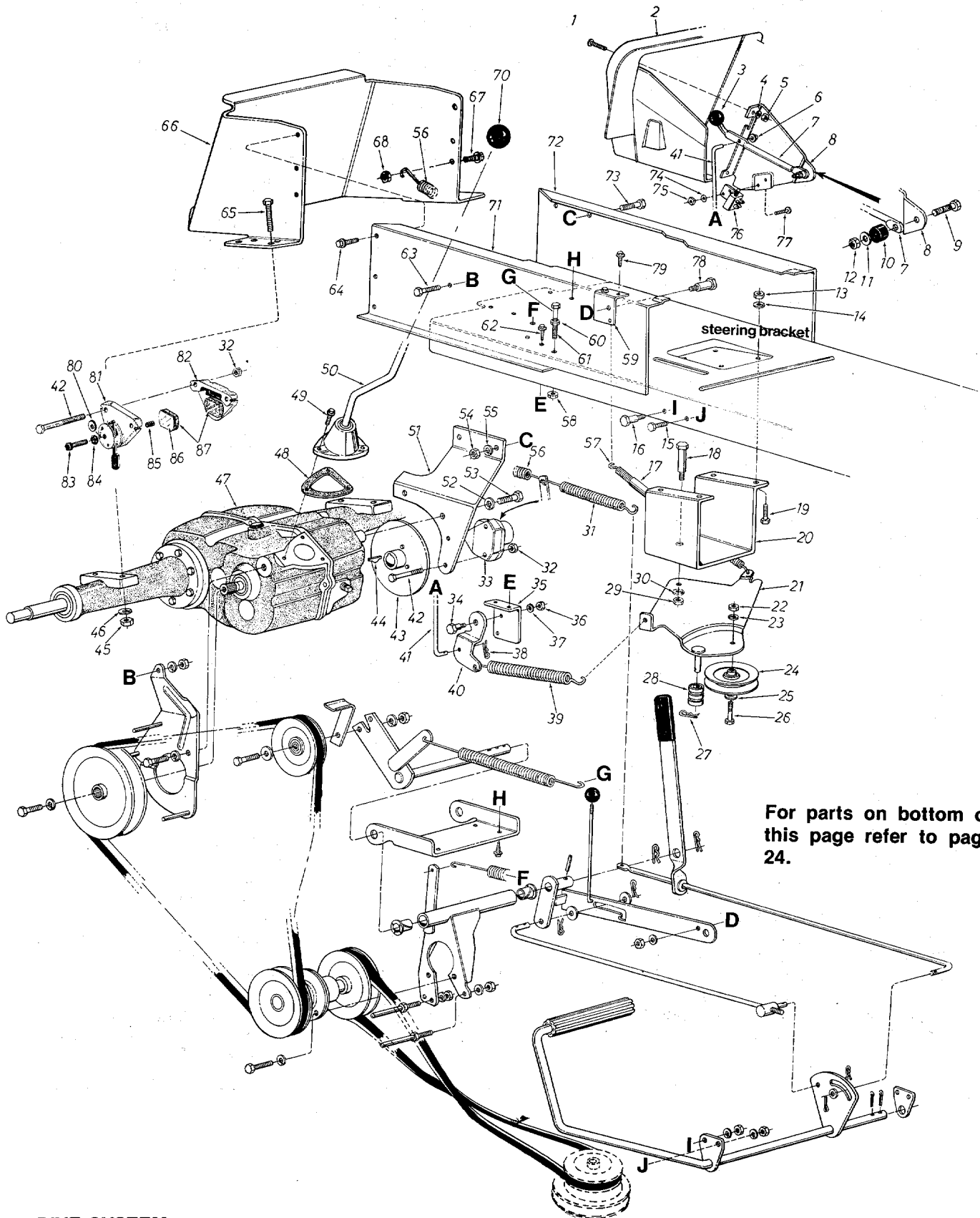

DRIVE SYSTEM

PARTS LIST FOR MODEL 149-820A

REF NO.	PART NO.	COLOR CODE	DESCRIPTION	NEW PART	REF. NO.	PART NO.	COLOR CODE	DESCRIPTION	NEW PART
1	710-0286		Truss Mach. Scr. 1/4-20 x .50" Lg.*		45	712-0798		Hex Nut 3/8-16 Thd.*	
2	13843		Dash Panel Ass'y.	N	46	736-0169		L-Wash. 3/8" Scr.*	
3	720-0165		Knob—Blade Clutch		47	—		Transaxle (See page 32 for Breakdown)	
4	736-0329		L-Wash. 1/4" Scr.*		48	—		Part of Ref. No. 47	
5	712-0287		Hex Nut 1/4-20 Thd.*		49	—		Part of Ref. No. 47	
6	726-0106		Push Cap 1/4" Rod		50	—		Part of Ref. No. 47	
7	747-0157		Blade Clutch Lever		51	13012		Transaxle Support	
8	13950		Deck Clutch Control Brkt.	N	52	736-0169		L-Wash. 3/8" Scr.*	
9	710-0106		Hex Scr. 1/4-20 x 1.25" Lg.*		53	710-0216		Hex Scr. 3/8-16 x .75" Lg.*	
10	735-0126		Rubber Wash. .330 I.D. x .87		54	712-0798		Hex Nut 3/8-16 Thd.*	
11	736-0173		FI-Wash. 1/4" I.D. x .75" O.D. x .057		55	736-0169		L-Wash. 3/8" Scr.*	
12	712-0107		Hex Cent. L-Nut 1/4-20 Thd.		56	732-0157		Ext. Spring—Brake Return	
13	712-0267		Hex Nut 5/16-18 Thd.*		57	732-0308		Ext. Spring—Deck Idler Return	
14	736-0119		L-Wash. 5/16" Scr.*		58	712-0267		Hex Nut 5/16-18 Thd.*	
15	710-0201		Hex Scr. 3/8-16 x .62" Lg.*		59	13833		Parking Brake Cam. Mtg. Brkt.	N
16	738-0234		Shld. Scr. 1/2" Dia. x .395 Lg. 3/8-16		60	712-0267		Hex Nut 5/16-18 Thd.*	
17	731-0483		Convoluted Conduit .50 I.D. x 4" Lg.		61	710-0442		Hex Scr. 5/16-18 x 1.50" Lg.*	
18	738-0155		Shld. Scr. 7/16 Dia. x .16" 5/16-18		62	710-0599		Hex Thd. Rolling Scr. 1/4-20 x .50" Lg.	
19	710-0376		Hex Scr. 5/16-18 x 1.00" Lg.*		63	710-0216		Hex Scr. 3/8-16 x .75" Lg.*	
20	13826		Idler Mtg. Brkt.—Deck	N	64	710-0600		Hex Thd. Rolling Scr. 5/16-24 x .50" Lg.	
21	13893		Idler Brkt. Ass'y.	N	65	710-0344		Hex Scr. 3/8-16 x 1.50" Lg.*	
22	712-0798		Hex Nut 3/8-16 Thd.*	N	66	13813		Hitch Plate	
23	736-0169		L-Wash. 3/8" Scr.*		67	710-0601		Hex Thd. Rolling Scr. 5/16-24 x .75" Lg.	
24	756-0293		4"-V Idler Pulley		68	712-0123		Hex Nut 5/16-24 Thd.*	
25	736-0300		FI-Wash. 3/8" I.D.		70	720-0165		Knob—Transaxle	
26	710-0342		Hex Scr. 3/8-16 x 1.25" Lg.*		71	13848		Side Panel Upper Frame—R.H.	N
27	714-0104		Hairpin Cotter 5/16" Rod		72	13847		Side Panel Upper Frame—L.H.	N
28	748-0278		Spacer	N	73	710-0216		Hex Scr. 3/8-16 x .75" Lg.*	
29	712-0267		Hex Nut 5/16-18 Thd.*		74	736-0147		Ext. L-Wash. #10 Scr.*	
30	736-0119		L-Wash. 5/16" Scr.*		75	712-0121		Hex Nut #10-24 Thd.*	
31	732-0260		Ext. Spring—Brake Rod		76	725-0465		Safety Switch (Deck)	
32	712-0375		Hex Cent. L-Nut 3/8-16 Thd.		77	710-0473		Truss Mach. Scr. #10-24 x .50" Lg.*	
33	761-0178		Disc Brake Caliper Ass'y.	N	78	738-0155		Shld. Scr. 7/16" Dia. x .16" Lg. 5/16-18	
34	738-0155		Shld. Scr. 7/16" Dia. x .16" Lg. 5/16-18		79	710-0599		Hex Thd. Rolling Scr. 1/4-20 x .50" Lg.	
35	13833		Parking Brake Cam Mtg. Brkt.	N	80	HU-20-9764		Washer	
36	712-0267		Hex Nut 5/16-18 Thd.*		81	HU-3770066		Housing with Lever & Pin	
37	736-0119		L-Wash. 5/16" Scr.*		82	HU-16-13807		Anvil	
38	714-0104		Hairpin Cotter 5/16" Dia.		83	HU-39-13775		Pin, Adjuster	
39	732-0262		Ext. Spring—Deck Control		84	HU-37-13818		Nut	
40	13887		Deck Control Pivot Brkt.	N	85	HU-39-13774		Pin, Actuator	
41	747-0307		Deck Control Rod	N	86	HU-25-13808		Backing Plate	
42	710-0937		Hex Scr. 3/8-16 x 2.50" Lg.*		87	HU-24-13772		Lining	
43	761-0142		Hub & Disc. Ass'y. (For Brake)						
44	714-0137		Hi-Pro Key 3/16 x 3/4" Lg.						

*For faster service obtain standard nuts, bolts and washers locally. If these items cannot be obtained locally, order by part number and size shown on parts list.

(463—Top Flite Red)

When ordering parts if color is important, use the appropriate color code listed above. (e.g. 12369—463—Top Flite Red)

149-820A

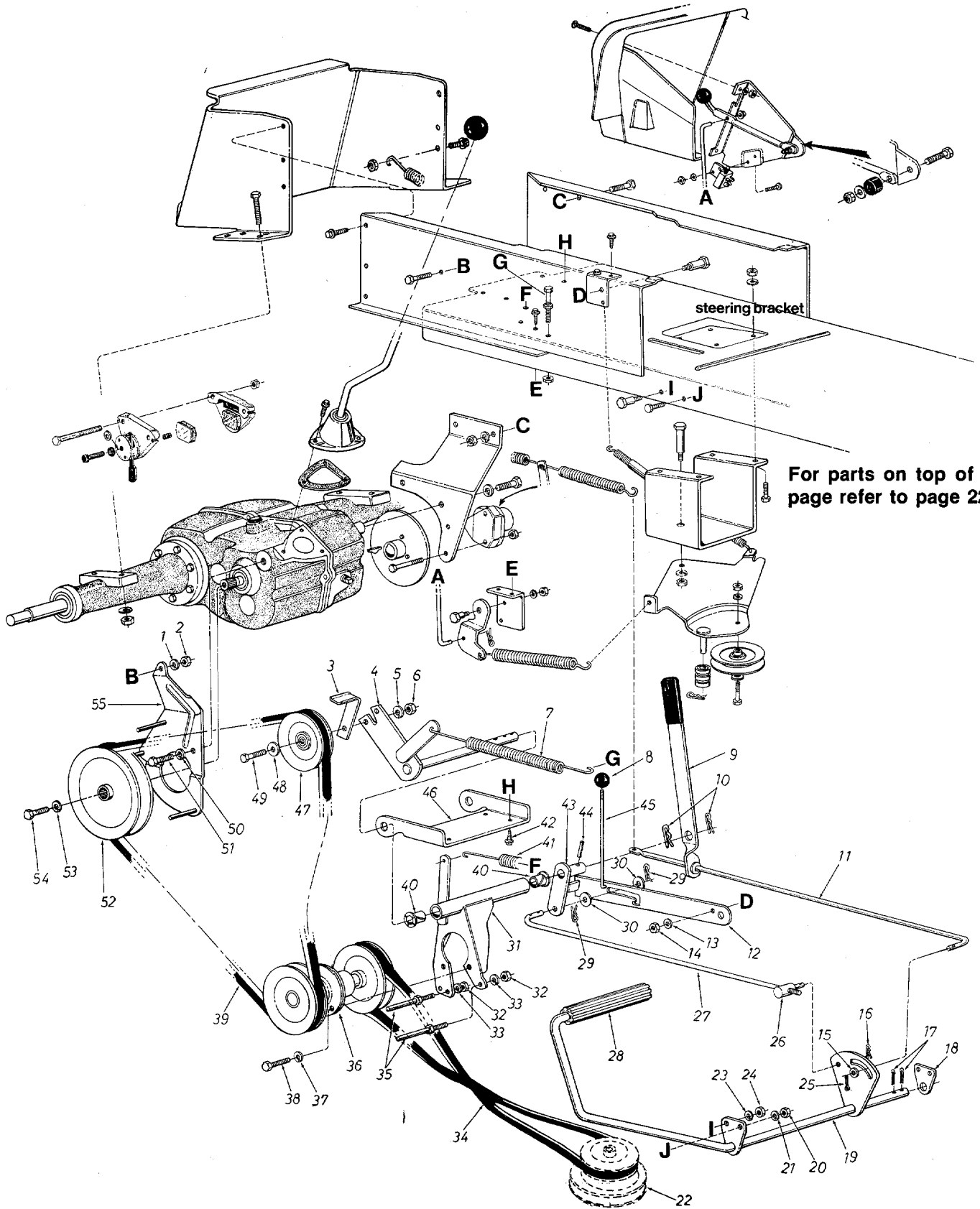

For parts on top of this page refer to page 22.

DRIVE SYSTEM

PARTS LIST FOR MODEL 149-820A

REF. NO.	PART NO.	COLOR CODE	DESCRIPTION	NEW PART	REF. NO.	PART NO.	COLOR CODE	DESCRIPTION	NEW PART
1	736-0169		L-Wash. 3/8" Scr.*		31	13823		Jack Shaft Mtg. Brkt. Ass'y.	N
2	712-0798		Hex Nut 3/8-16 Thd.*		32	712-0798		Hex Nut 3/8-16 Thd.*	
3	13819		Belt Guard (Clutch Idler)	N	33	736-0169		L-Wash. 3/8" Scr.*	
4	13815		Clutch Brkt. Ass'y.	N	34	754-0245		"V"-Belt 1/2 x 59" Lg.	
5	736-0169		L-Wash. 3/8" Scr.*					(Kevlar)	N
6	712-0798		Hex Nut 3/8-16 Thd.*		35	711-0696		Stud 3/8-16 x 3.62" Lg.	
7	732-0202 384		Ext. Spring (Drive Idler)					Special	N
8	720-0166		Knob (Parking Brake)		36	756-0324		Jack Shaft Ass'y.	N
9	714-0145		Hairpin Cotter 3/8" Rod		37	736-0119		L-Wash. 5/16" Scr.*	
10	714-0117		Hairpin Cotter 5/8" Dia.		38	710-0198		Hex Sem Scr. 5/16-18 x .75"	
11	747-0304		Brake Rod	N				Lg.*	
12	13832		Parking Brake Cam	N	39	754-0244		"V"-Belt 1/2 x 40" Lg.	
13	736-0275		FI-Wash. 5/16" Scr.					(Kevlar)	N
14	712-0267		Hex Nut 5/16-18 Thd.*		40	741-0295		Nyliner 5/8" I.D. x .88" Lg.	N
15	736-0275		FI-Wash. 5/16" Scr.		41	732-0153		Ext. Spring (Jack Shaft)	
16	714-0145		Hairpin Cotter 3/8" Rod		42	710-0599		Hex Thd. Rolling Scr. 1/4-20 x	
17	714-0474		Cotter Pin 1/8" Dia. x 1.00"					.50" Lg.	
18	13859		Clutch Rod Brg. Brkt.	N	43	13871		Clutch-Idler Horn Ass'y.	N
19	13856		Clutch—Brake Pedal Ass'y.	N	44	715-0108		Spring Pin Spiral 1/4" Dia. x	
20	712-0798		Hex Nut 3/8-16 Thd.*					1.00" Lg.	
21	736-0169		L-Wash. 3/8" Scr.*		45	747-0300		Parking Brake Link	N
22	756-0328		Engine Pulley 4.75 & 5.56	N	46	13822		Idler Mtg. Brkt.—Drive	N
23	736-0169		L-Wash. 3/8" Scr.*		47	756-0293		4" "V"-Idler Pulley	
24	712-0798		Hex Nut 3/8-16 Thd.*		48	736-0300		FI-Wash. 3/8" I.D.	
25	714-0115		Cotter Pin 3/32" Dia. x .75"		49	710-0342		Hex Scr. 3/8-16 x 1.25" Lg.*	
			Lg.*		50	736-0169		L-Wash. 3/8" Scr.*	
26	711-0198		Pivot Bushing		51	710-0216		Hex Scr. 3/8-16 x .75" Lg.*	
27	747-0306		Brake Cam Rod	N	52	756-0332		"V"-Pulley 7.0" O.D.	
28	735-0196		Foot Pad	N				(Transaxle)	N
29	714-0145		Hairpin Cotter 3/8" Rod		53	736-0169		L-Wash. 3/8" Scr.*	
30	736-0101		FI-Wash. 3/8" I.D. x 1.00"		54	710-0180		Hex Scr. 3/8-24 x .75" Lg.*	
			O.D. x .030		55	13829		Belt Guard Ass'y.	N

149-820A

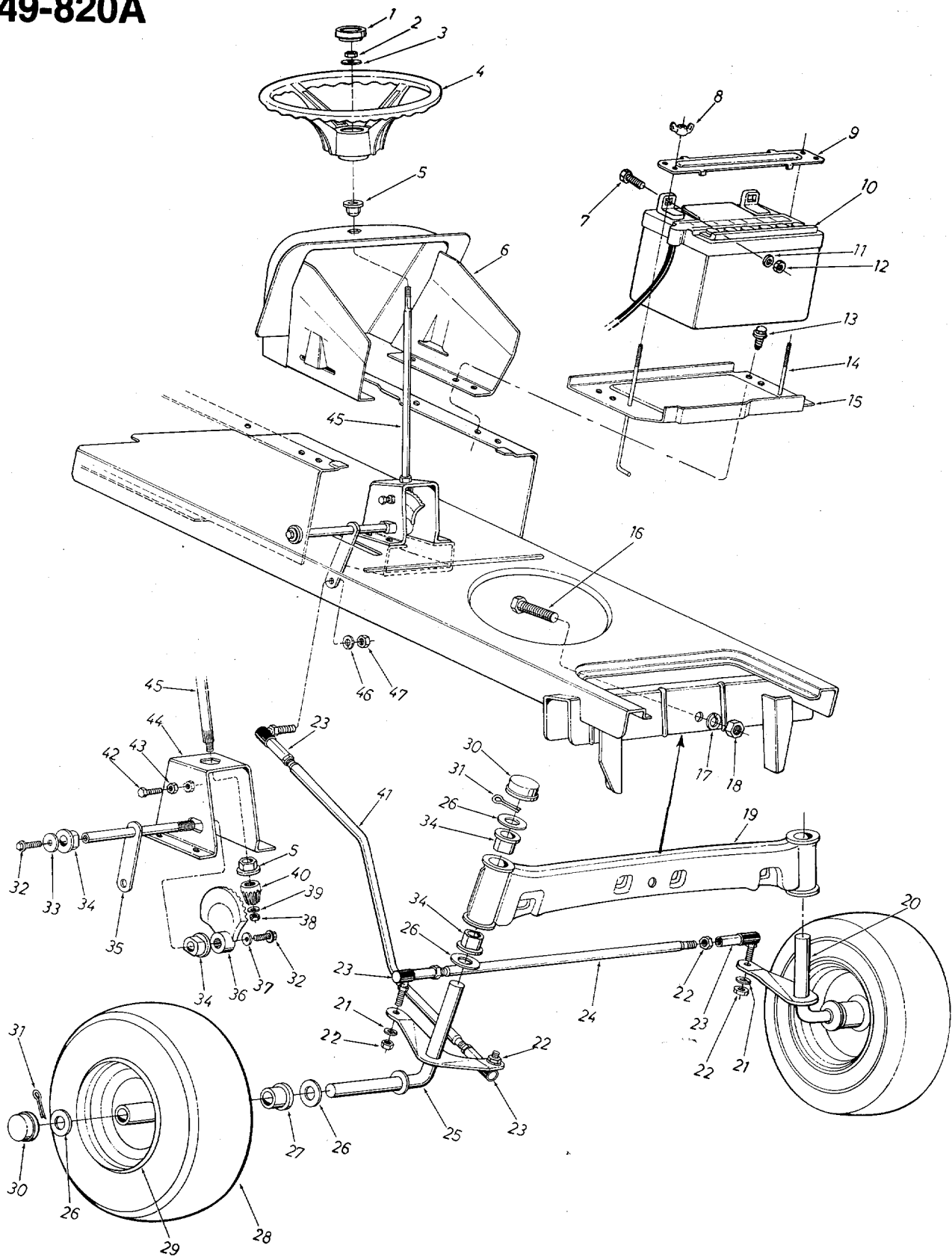

STEERING

PARTS LIST FOR MODEL 149-820A

REF. NO.	PART NO.	COLOR CODE	DESCRIPTION	NEW PART	REF. NO.	PART NO.	COLOR CODE	DESCRIPTION	NEW PART
1	731-0220		Steering Wheel Cap		28	734-0960		Front Wheel Ass'y. Comp.	N
2	712-0158		Hex Cent. L-Nut 5/16-18 Thd.		29	734-0961		Front Wheel Rim Only	
3	736-0275		FI-Wash. 5/16" I.D. x 1.00" O.D. x .057			734-0498		Front Wheel Tire Only 15 x 6.00	
4	731-0356		Steering Wheel			734-0255		Air Valve	
5	741-0225		Plastic Hex Bearing 5/8" I.D.		30	731-0484		Dust Cover	
6	13843		Dash Panel Ass'y.	N	31	714-0121		Cotter Pin 5/32" Dia. x 1.00" Lg.*	
7	710-0258		Hex Scr. 1/4-20 x .62" Lg.		32	710-0180		Hex Scr. 3/8-24 x .75" Lg. Grade 5	
8	712-0113		Wing Nut Plastic 1/4-20 Thd.	N				FI-Wash. 3/8 I.D. x 1.25 O.D. x .090	
9	13959		Battery Hold Down	N	33	736-0133		Flange Double "D" Brg. .753 I.D.	
10	725-0661		12-V Battery					Steering Arm Shaft Ass'y.	
11	736-0329		L-Wash. 1/4" Scr.*		34	741-0199		Side Gear—Steering	
12	712-0287		Hex Nut 1/4-20 Thd.*					Bell-Wash. 3/8" I.D.	
13	710-0599		Hex Thd. Rolling Scr. 1/4-20 x .50" Lg.		35	12749		Hex Cent. L-Nut 5/16-24 Thd.	
14	711-0222		Battery Hold Down Rod		36	748-0236		FI-Wash. 5/16" I.D. x 62 O.D. x .059	
15	13379		Battery Plate		37	736-0105		Pinion Gear—Steering	
16	710-0533		Hex Scr. 5/8-18 x 2.50" Lg.*		38	712-0237		Drag Link	N
17	736-0158		L-Wash. 5/8" Scr.*		39	736-0264		Hex Nylon Scr. 3/8-16 x 1.25" Lg.	
18	712-0923		Hex Cent. L-Nut 5/8-18 Thd.	N	40	748-0237		Hex Nut 3/8-16 Thd.*	
19	13865		Front Pivot Bar Ass'y.	N	41	747-0302		Steering Gear Sup. Ass'y.	
20	13839		Front Axle Ass'y.—L.H.		42	710-0670		Steering Shaft	
21	736-0169		L-Wash. 3/8" Scr.*					L-Wash. 3/8" Scr.*	
22	712-0241		Hex Nut 3/8-24 Thd.*		43	712-0798		Hex Nut 3/8-24 Thd.*	
23	736-0156		Ball Joint Ass'y.		44	12850			
24	747-0301		Tie Rod	N	45	738-0317			
25	13838		Front Axle Ass'y.—R.H.	N	46	736-0169			
26	736-0316		FI-Wash. .780 I.D. x 1.59 O.D.		47	712-0241			
27	741-0293		Flange Bearing						

149-820A

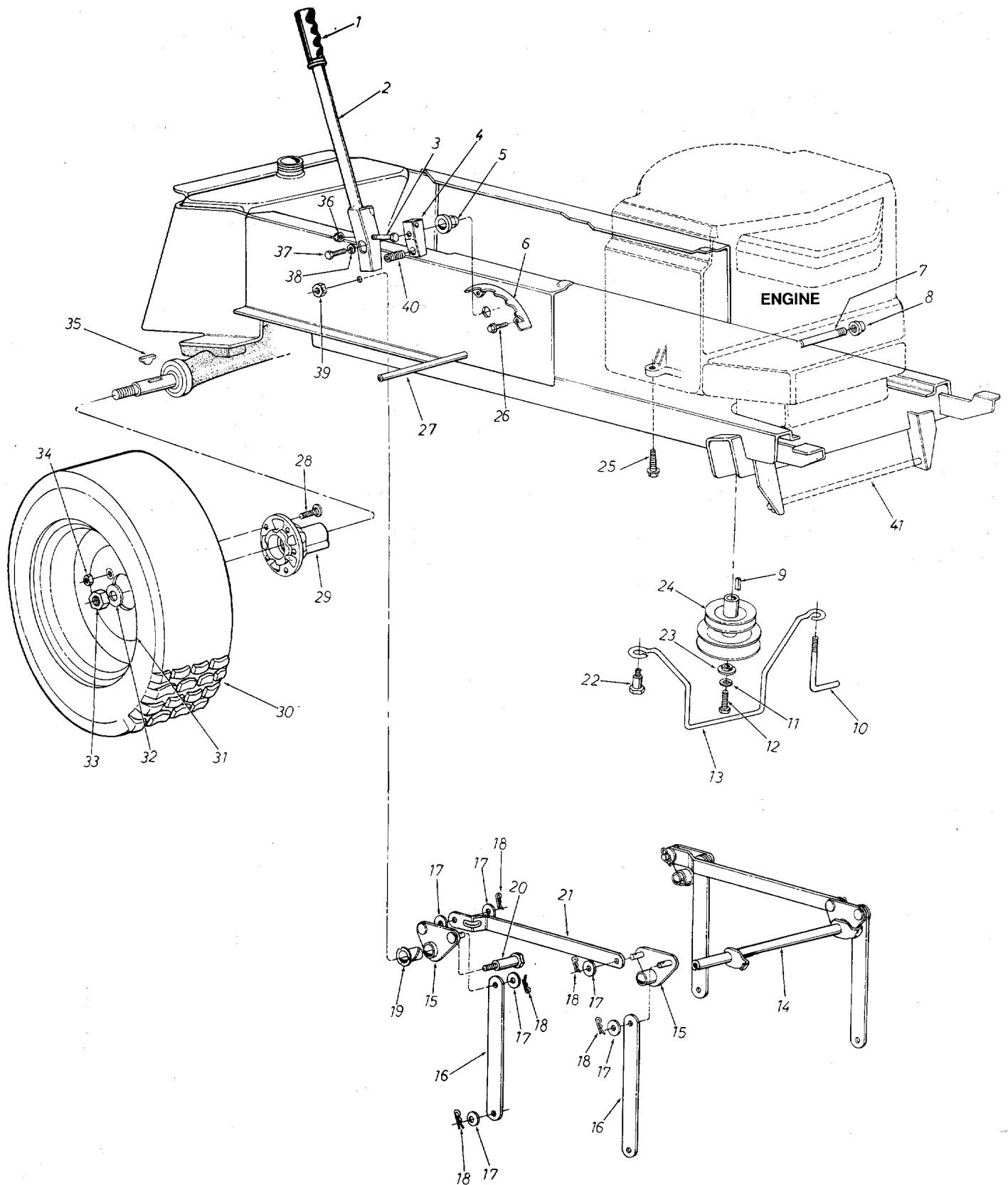

DECK LINKAGE

PARTS LIST FOR MODEL 149-820A

REF. NO.	PART NO.	COLOR CODE	DESCRIPTION	NEW PART
1	720-0157		Grip	
2	13884		Lift Handle Ass'y.	N
3	710-0442		Hex Scr. 5/16-18 x 1.50" Lg.*	
4	748-0274		Lift Shaft Drive	N
5	741-0225		Plastic Hex Brg. 5/8" I.D.	
6	13873		Index Brkt. Deck Lift	N
7	737-0164		Pipe Nipple 3/8-18 Npt.	
8	737-0143		Pipe Cap 3/8-18 Npt.	
9	714-0118		Sq. Key 1/4" x 1/4" x 1.50" Lg.	
10	747-0216		Belt Guard Lock Pin	
11	736-0171		L-Wash. 7/16" Scr.*	
12	710-0757		Hex Scr. 7/16-20 x 1.50" Lg.	
13	747-0299		Belt Guard	N
14	13889		Lift Shaft Ass'y.	N
15	13895		Lift Pivot Brkt. Ass'y.	N
16	13791		Link (Deck)	N
17	736-0192		FI-Wash. 1/2" I.D. x 1.00" O.D. x .090	
18	714-0101		Hairpin Cotter 1/2" Dia.	
19	741-0295		Nyliner 5/8" I.D. x .88" Lg.	N
20	738-0445		Shld Scr. 5/8" Dia. x .96" Lg. 3/8-16	
21	13790		Connecting Link	N
22	738-0296		Shld. Scr. .437 Dia. x .268 Lg. 5/16-18	
23	748-0277		Step Wash. (Special)	N
24	756-0328		Two-Step Engine Pulley 4.75" & 5.56	N
25	710-0502		Hex Wash. Hd. Scr. 3/8-16 x 1.25" Lg.	
26	710-0600		Hex Thd. Rolling Scr. 5/16-24 x .50" Lg.	
27	738-0435		Running Board Rod	N
28	710-0617		Rd. Hd. Ribbed Neck Scr. 3/8-24 x 1.00" Lg. (Service Only)	
29	719-0236		Rear Wheel Hub Ass'y. with Studs	
30	734-0966		Rear Wheel Ass'y. Comp.	N
31	734-0785		Rear Wheel Rim Only	
	734-0967		Rear Wheel Tire only 22 x 7.50	N
32	748-0160		Spacer	
33	712-0288		Hex Ins. L-Nut 3/4-16 Thd.	
34	712-0193		Hex Cone Nut 3/8-24 Thd.	
35	714-0146		#27 Woodruff Key 1/4 x 2.12 H.T.	
36	712-0158		Hex Cent. L-Nut 5/16-18 Thd.	
37	710-0237		Hex Scr. 5/16-24 x .62" Lg.*	
38	736-0119		L-Wash. 5/16" Scr.*	
39	712-0181		Hex Top L-Nut 3/8-16 Thd.	
40	732-0369		Compression Spring	
41	738-0392		Deck Connecting Rod	N

The engine is not under warranty by the mower manufacturer. If repairs or service is needed on the engine, please contact your nearest authorized engine service outlet. Check the "Yellow Pages" of your telephone book under "Engines — Gasoline."



199-935A (OPTIONAL 44" DECK)

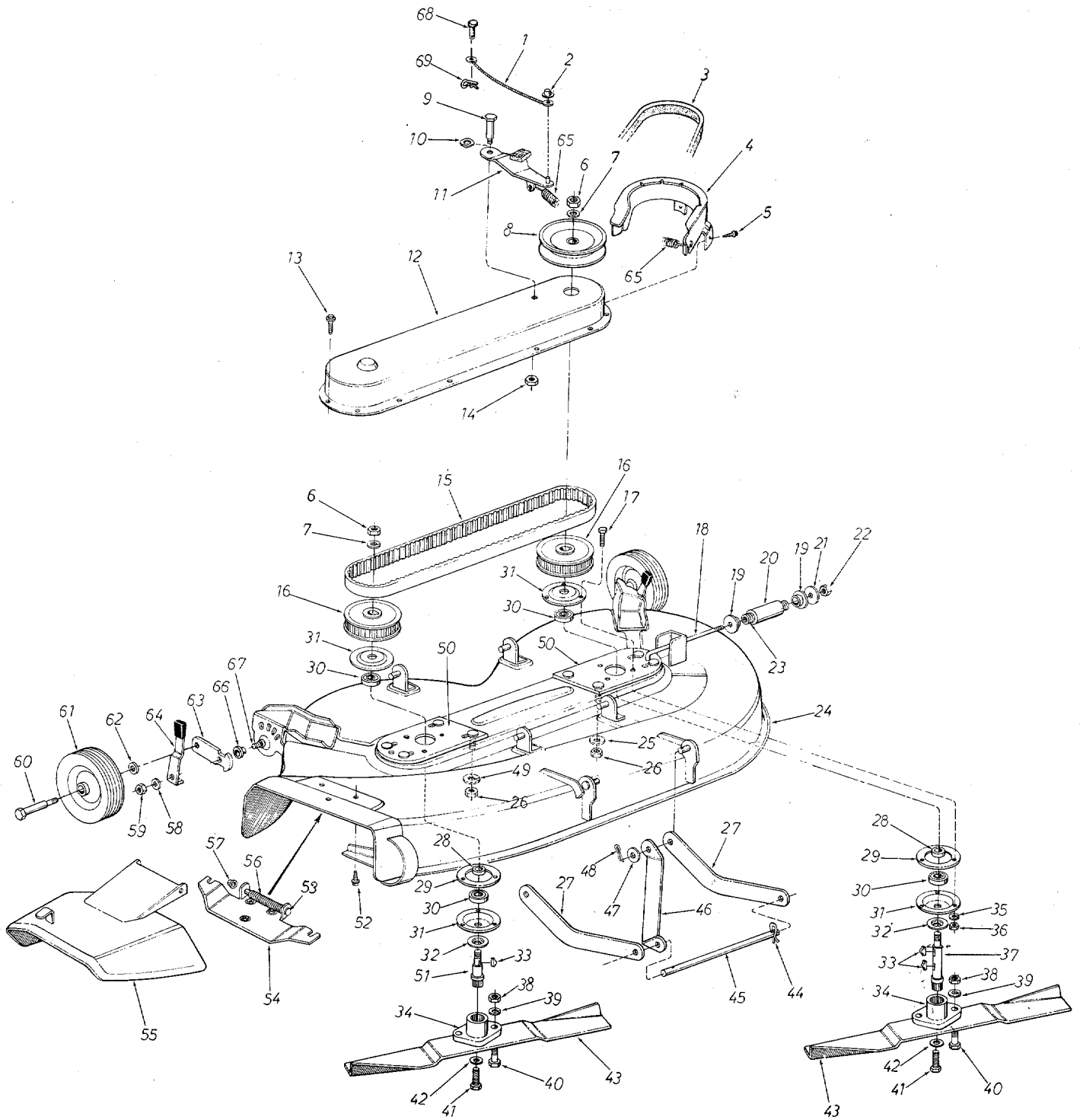

CUTTING DECK

OPTIONAL

PARTS LIST FOR MODEL 199-935A 44" DECK

REF. NO.	PART NO.	COLOR CODE	DESCRIPTION	NEW PART	REF. NO.	PART NO.	COLOR CODE	DESCRIPTION	NEW PART
1	746-0237		Brake Cable Ass'y. (Deck)	N	37	738-0436		Blade Spindle—L.H.	N
2	726-0106		Push Cap 1/4" Stud		38	712-0123		Hex Nut 5/16-24 Thd.*	
3	754-0230		"V"-Belt 1/2" x 56" Lg.		39	736-0119		L-Wash. 5/16" Scr.*	
4	13910		Belt Guard (Deck)	N	40	710-0117		Hex Scr. 5/16-24 x 1.00" Lg.	
5	710-0599		Hex Thd. Rolling 1/4-20 x .50" Lg.		41	710-0180		Grade 5 Hex Scr. 3/8-24 x .75" Lg.	
6	712-0261		Hex Jam L-Nut 5/8-11 Thd.		42	736-0217		Grade 5 L-Wash. 3/8" Scr. H.D.	
7	736-0317		Belle. Wash. 5/8" I.D. x 1.25 O.D.		43	742-0125		22" Blade	
8	756-0329		Deck Drive "V"-Pulley	N	44	714-0149		Hairpin Cotter	
9	738-0140		Shld. Scr. .437" Dia. x .180" Lg. 5/16-18		45	738-0392		Deck Connecting Rod	N
10	736-0141		Wave Wash. 7/16" Scr.		46	13867		Diagonal Brace	N
11	13908		Spindle Brake Arm Ass'y.	N	47	736-0192		FI-Wash. 1/2" I.D. x 1.00" O.D. x .090	
12	13870		Belt Cover	N	48	714-0111		Cotter Pin 3/32" Dia. x 1.00" Lg.*	
13	710-0653		Hex Thd. Rolling Scr. 1/4-20 x .38" Lg.		49	736-0105		Belle. Wash. 3/8" Scr.	
14	712-0158		Hex Cent. L-Nut 5/16-18 Thd.	N	50	13868		Spindle Plate Ass'y.	N
15	754-0246		Timing Belt #1440-8M-20	N	51	738-0437		Blade Spindle—R.H.	N
16	756-0334		Sprocket Pulley Ass'y.		52	710-0599		Hex Wash. Hd. Self Tap Scr. 1/4-20 x .50" Lg.	
17	710-0322		Hex Sems Scr. 5/16-18 x 1.00" Lg.*		53	711-0571		Hinge Pin	
18	710-0754		Adjustment Scr.	N	54	11396		Grass Catcher Adapter Plate	
19	738-0347		Shld. Spacer (Special)		55	11633		Chute Cover Ass'y.	
20	750-0455		Spacer—Adj. Scr.	N	56	732-0261		Torsion Spring	
21	736-0231		FI-Wash. 5/16" I.D. x 1.125" O.D.		57	726-0106		Push Nut 1/4" Rod	
22	712-0267		Hex Nut 5/16-18 Thd.*		58	736-0219		Belleville Wash.	
23	732-0377		Compression Spring	N	59	712-0214		Hex Nut 3/8-24 Thd.*	
24	13861		44" Deck Ass'y.	N	60	738-0373		Shld. Scr. .498 Dia. x 1.53" Lg. 3/8-16	
25	736-0105		Belleville Wash. 3/8" I.D.		61	734-0965		Wheel Ass'y. Comp. 6" (Deck)	N
26	712-0241		Hex Nut 3/8-24 Thd.*	N	62	736-0105		Belleville Wash. 3/8" I.D.	
27	13866		Deck Stabilizer		63	10937		Wheel Pivot Bar	
28	750-0456		Spacer		64	10949		Spring Lever Ass'y. with Knob	
29	09164		Reinforcement Plate		65	732-0265		Extension Spring	
30	741-0919		Ball Bearing		66	748-0279		Shld. Spacer	
31	08253		Bearing Housing		67	710-0191		Hex Scr. 3/8-24 x 1.25" Lg. Grade 5	
32	13703		Bearing Shield		68	711-0701		Clevis Pin 1/4" Dia. x 1.00" Lg.	
33	714-0126		#9 Hi-Pro Key 3/16 x 3/4" Dia.		69	714-0100		Hairpin Cotter 1/4" Dia.	
34	748-0235		Blade Adapter 3/4" Spindle						
35	736-0119		L-Wash. 5/16" Scr.*						
36	712-0267		Hex Nut 5/16-18 Thd.*						
					70	742-0205		22.5" Blade	N

(Problem with uncut strips)

149-820A

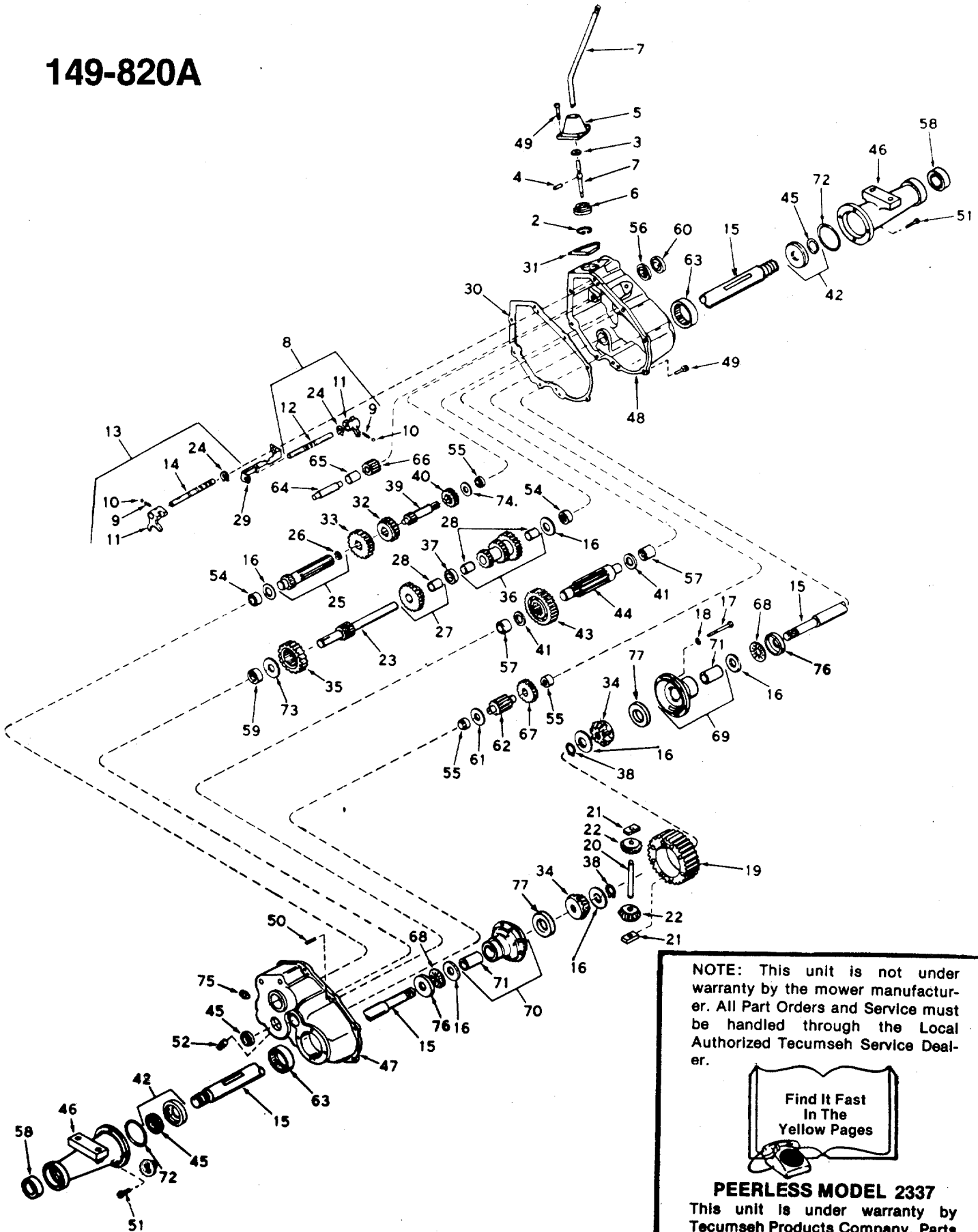

NOTE: This unit is not under warranty by the mower manufacturer. All Part Orders and Service must be handled through the Local Authorized Tecumseh Service Dealer.



PEERLESS MODEL 2337
 This unit is under warranty by Tecumseh Products Company. Parts and Service are available through all Tecumseh, Lauson Power Products Service Dealers. Check the "Yellow Pages" of your telephone directory under "Engines—Gasoline."

PARTS LIST FOR TRANSAXLE MODEL 2337

REF. NO.	PART NO.	DESCRIPTION	REF. NO.	PART NO.	DESCRIPTION
2	PE-792016	Ring, Snap	40	PE-778024	Spur Gear, Input Shaft
3	PE-792001	Ring, Quad	41	PE-780052	Washer, Thrust
4	PE-792049	Pin, Roll	42	PE-788021	Seal and Retainer Ass'y., Oil (Incl. No. 45)
5	PE-784093	Housing, Shift Lever	43	PE-778036	Gear, Output
6	PE-784094	Keeper, Shift Lever	44	PE-776028	Pinion, Output
7	PE-3471-PI	Lever, Shift*	45	PE-788008	Seal, Oil
8	PE-784054	Rod Ass'y., Shift (Incl. Nos. 9 thru 12 and 24)	46	PE-782025	Housing, Axle
9	PE-792003	Spring	47	PE-772016A	Cover Ass'y., Transaxle (Incl. Nos. 54, 55, 57, 59 and 63)
10	PE-792004	Ball, Steel	48	PE-770012	Case Ass'y., Transaxle (Incl. Nos. 54, 55, 57 and 63)
11	PE-784004	Fork, Shifter	49	PE-792007	Scr., Socket Hd. Cap 1/4-20 x 3/4
12	PE-784055	Rod, Shifter (3rd and 4th)	50	PE-786026	Pin, Dowel
13	PE-784056	Rod Ass'y., Shift (Incl. Nos. 9, 10, 11, 14 and 24)	51	PE-792037	Scr., Hex Hd. Sems, 5/16-18 x 1
14	PE-784057	Rod, Shifter (Low)	52	PE-792019	Plug, Magnetic Drain
15	PE-774361	Axle	54	PE-780049	Bearing, Needle
16	PE-780042	Washer, Thrust	55	PE-530105	Bearing, Needle
17	PE-792005	Scr. Hex Hd. Cap 1/4-20 x 2 1/2	56	PE-780024	Bearing, Ball
18	PE-792006	L-Wash. 1/4"	57	PE-780047	Bearing, Needle
19	PE-778033A	Gear, Ring	58	PE-780050	Bearing, Ball
20	PE-786019	Pin, Drive	59	PE-780046	Bearing, Needle
21	PE-786027	Block, Drive	60	PE-788025	Seal, Oil
22	PE-778094	Pinion, Bevel	61	PE-780001	Washer
23	PE-776029A	Shaft and Gear, Brake	62	PE-776031	Shaft and Pinion
24	PE-792017	Ring, Snap	64	PE-780048	Bearing, Needle
25	PE-776026	Shaft and Brg. Ass'y., Pinion (Incl. No. 26)	64	PE-776030	Shaft, Reverse Idler
26	PE-780018	Bearing, Needle	65	PE-786025	Spacer, Reverse Idler
27	PE-778034	Gear Cluster Ass'y. (Incl. No. 28)	66	PE-778016	Idler, Reverse
28	PE-780053	Bushing	67	PE-778038	Spur Gear (22 teeth)
29	PE-784074	Stop, Shifter	68	PE-780039	Bearing, Thrust
30	PE-788023	Gasket, Case and Cover	69	PE-774072A	Carrier Ass'y., Differential (Incl. No. 71)
31	PE-788022	Gasket, Shifter Lever Housing	70	PE-774071A	Carrier Ass'y., Differential (Incl. No. 71)
32	PE-778019	Gear, Shifting (3rd and 4th)	71	PE-780041	Bushing
33	PE-778020	Gear, Shifting (1st, 2nd and Rev.)	72	PE-788024	"O" Ring
34	PE-778095	Gear, Bevel	73	PE-780007	Washer, Thrust
35	PE-778037	Gear, Idler	74	PE-780051	Washer, Thrust
36	PE-778035	Gear Cluster Ass'y. (Incl. No. 28)	75	PE-792010	Plug, Pipe
37	PE-786024	Spacer	76	PE-780075	Race, Thrust
38	PE-792018	Ring, Snap	77	PE-780107	Washer
39	PE-776175	Shaft, Input			

*Shift lever is not shipped with transaxle. Order separate.

149-820A

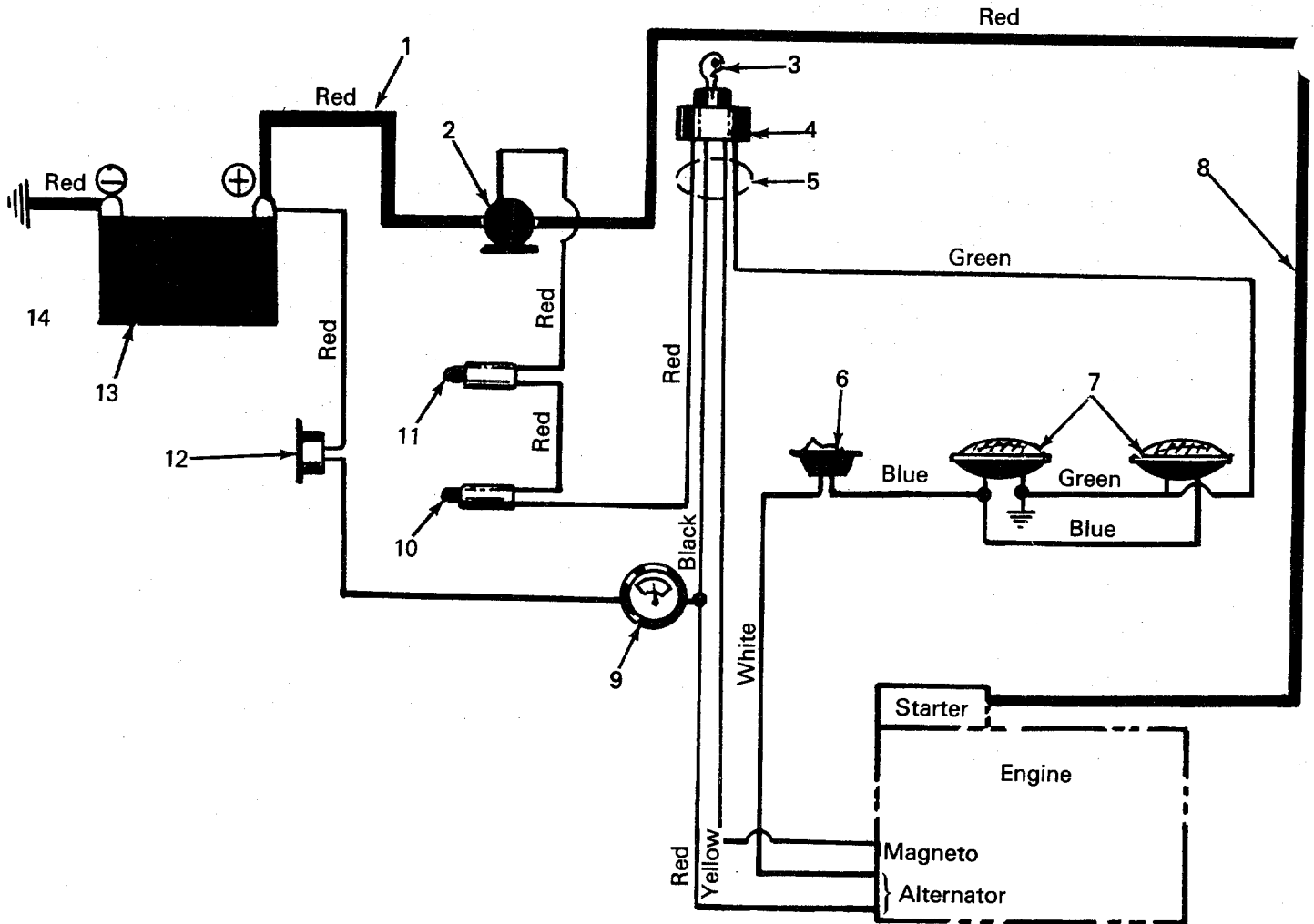

PARTS LIST FOR ELECTRICAL SYSTEM 149-820A

REF. NO.	PART NO.	COLOR CODE	DESCRIPTION	NEW PART
1	725-0563		Electric Cable	
2	725-0530		Solenoid	
3	725-0201		Ignition Key	
4	725-0267		Ignition Switch	
5	725-0666		Wire Harness	N
6	725-0634		Light Switch	N
7	725-0222		Headlight	
8	725-0561		Electric Cable	
9	725-0119		Ammeter	
10	725-0465		Safety Switch	
11	725-0268		Safety Switch—Black N.O.	
12	725-0459		Circuit Breaker	
13	725-0661		12 V-Battery	N
14	725-0563		Electric Cable	

PARTS INFORMATION

POWER EQUIPMENT PARTS AND SERVICE

Parts and service for all MTD manufactured power equipment are available through the authorized service firms listed below. All orders should specify the model number of your unit, parts number, description of parts and the quantity of each part required.

ALABAMA	BIRMINGHAM	
Auto Electric & Carburetor Co.	2625 4th Ave. S.	35233
ARKANSAS	NORTH LITTLE ROCK	
Sutton's Lawn Mower Shop	Rt. 4 Box 368	72117
	FORT SMITH	
Mity Mite Motors, Inc.	2515 Towson Ave.	72901
CALIFORNIA	PORTERVILLE	
Billious	75 North D Street	93257
	SAN BERNARDINO	
Lawn Mower Supply Co.	25608 E. Baseline	92410
	SAN FRANCISCO	
J.W. Jewett Co.	981 Folsom St.	94107
	SACRAMENTO	
Luttig & Severson	2030 28th St.	95818
COLORADO	DENVER	
South Denver Lawn Equip.	527 West Evans	80223
FLORIDA	JACKSONVILLE	
Radco Distributors	2403 Market St.	32206
	CORAL GABLES	
Moz-All of Florida, Inc.	365 Greco Ave.	33146
GEORGIA	EAST POINT	
East Point Cycle & Key	2834 Church St.	30344
ILLINOIS	LYONS	
Keen Edge Co.	8615 Ogden Ave.	60534
INDIANA	ELKHART	
Parts & Sales Inc.	2101 Industrial Pkwy.	46514
IOWA	DUBUQUE	
Power Lawn & Garden Equip.	2551 J.F. Kennedy	52001
LOUISIANA	NEW ORLEANS	
Suhren Engine Co.	8330 Earhart Blvd.	70118
MARYLAND	TAKOMA PARK	
Center Supply Co.	6867 New Hampshire Ave.	20012
MASSACHUSETTS	SPRINGFIELD	
Morton B. Collins Co.	300 Birnie Ave.	01107
MICHIGAN	MOUNT CLEMENS	
Power Equipment Dist.	36463 South Gratiot	48043
	LANSING	
Lorenz Service Co.	2500 S. Pennsylvania	48900
MINNESOTA	MINNETONKA	
Hance Distributing Inc.	11212 Wayzata Blvd.	55343
	ST. PAUL	
Power Tools Inc.	3771 Sibley Memorial Hwy.	55122
MISSISSIPPI	BILOXI	
Biloxi Sales & Service, Inc.	506 Caillavet St.	39533
MISSOURI	KANSAS CITY	
Automotive Equip. Service	3117 Holmes St.	64109
	ST. JOSEPH	
Ross-Frazier Supply Co.	8th and Monteray	64503
	ST. LOUIS	
Henzler, Inc.	2015 Lemay Ferry Rd.	63125
NEW JERSEY	BELLMAWR	
Lawnmower Parts Inc.	717 Creek Rd., P.O. Box 7.	08030
	RUTHERFORD	
Feld Distributor	28 Glen Rd.	07070
NEW YORK	CARTHAGE	
Gamble Dist., Inc.	West End Ave.	13619

BRIGGS AND STRATTON, TECUMSEH AND PEERLESS PARTS AND SERVICE

Briggs & Stratton, Tecumseh and Peerless parts and service should be handled by your nearest authorized engine service firm. Check the yellow pages of your telephone directory under the list. Engines—Gasoline, Briggs & Stratton or Tecumseh Lauson.

	SYRACUSE	
GTP Leisure Products Inc.	420 Marcellus St.	13204
NORTH CAROLINA	GREENSBORO	
Dixie Sales Company	327 Battleground Ave.	27402
	GOLDSBORO	
Smith Hardware Co.	515 N. George St.	27530
OHIO	WADSWORTH	
National Central	687 Seville Rd.	44281
	CLEVELAND	
Bleckrie, Inc.	7900 Lorain Ave.	44102
	CARROLL	
Stebe's Mid-State Mower Supply. Box 366-71 High St.		43112
	YOUNGSTOWN	
Burton Supply Co.	1301 Logan Ave. Box 929	44501
OKLAHOMA	MUSKOGEE	
Victory Motors, Inc.	605 S. Cherokee.	74401
	OKLAHOMA CITY	
Forest Sales Inc.	1039 NW 63rd St.	73116
	ADA	
Ada Auto Supply	301 E. 12th St.	74820
OREGON	PORTLAND	
Kenton Supply Co.	8216 N. Denver Ave.	97217
PENNSYLVANIA	CHESTER	
Stull Equipment Corp.	742 W. Front St.	19013
	HARRISBURG	
EECO Inc.	4021 N. 6th St.	17110
	PHILADELPHIA	
Thompson Rubber Co.	5222-24 N Fifth St.	19120
	PITTSBURGH	
Bluemont Co.	11125 Frankstown Rd.	15235
TENNESSEE	KNOXVILLE	
Master Repair Service	2423 Broadway, N.E.	37917
	MEMPHIS	
Memphis Cycle & Supply Co.	421 Monroe Ave.	381
American Sales & Service, Inc.	1922 Lynnbrook	38111
TEXAS	DALLAS	
Marr Brothers, Inc.	423 E. Jefferson.	75203
	HOUSTON	
Bullard Supply Co.	2409 Commerce St.	77003
	SAN ANTONIO	
Catto & Putty, Inc.	P.O. Box 2408	78206
	FORT WORTH	
Woodson Sales Corp.	1702 N. Sylvania	76111
UTAH	SALT LAKE CITY	
A-1 Engine & Mower Co.	437 E. 9th St.	84111
VERMONT	BURLINGTON	
Vermont Hdwe. Co. Inc.	180 Flynn Ave.	05401
VIRGINIA	RICHMOND	
RBI Corp.	963 Myers St.	23260
WASHINGTON	SEATTLE	
Bailey's Inc.	1414 14th Ave.	98122
WEST VIRGINIA	CHARLESTON	
Young's, Inc.	233 Virginia St., E.	25301
WISCONSIN	APPLETON	
Automotive Supply Co.	123 S. Linwood Ave.	54911

WARRANTY PARTS AND SERVICE POLICY

The purpose of warranty is to protect the customer from defects in workmanship and materials, defects which are NOT detected at the time of manufacture. It does not provide for the unlimited and unrestricted replacement of parts. Use and maintenance are the responsibility of the customer. The manufacturer cannot assume responsibility for conditions which it has no control. Simply put, if it's the manufacturer's fault, it's the manufacturer's responsibility; if it's the customer's fault, it's the customer's responsibility.

CLAIMS AGAINST THE MANUFACTURER'S WARRANTY INCLUDES

1. Replacement of Missing Parts on new equipment.
2. Replacement of Defective Parts within the warranty period.
3. Repair of Defects within the warranty period.

All claims MUST be substantiated with the following information:

1. Model Number of unit involved.
2. Date unit was purchased or first put into service.
3. Date of failure.
4. Nature of failure.